

# SERVICE MANUAL

AXOR INDUSTRIES®

ENGLISH



*Small package brushless servodrive*

## MINIMAGNUM®

*Twenty years of great motordrives*

**Projected Produced Assembled**

*100% Made in Italy*

**NO JOINT CONSTRUCTION**

<b>Release</b>	<b>Notes</b>
ver.1 rev. 06/'07	First preliminary edition.
ver.1 rev. 08/'07	First official edition.
ver.1 rev. 10/'07	Regen resistance value corrected.
ver.1 rev. 02/'08	External regen resistance dimensions insertion. Min/Max bus voltage values insertion. Regen resistance set point values insertion. Corrections.

All rights reserved. Reproduction in whole or in part is prohibited without prior written consent of the copyright owner. All specifications are subject to change without prior notification.

This manual has been carefully checked. However, Axor does not assume liability for errors or inaccuracies.

Print in Italy 02/2008



**THIS MANUAL CONTAINS A DESCRIPTION OF MiniMagnum™  
AND A GUIDELINES FOR THE DRIVE'S INSTALLATION;  
FOR MORE DETAILS SEE ENCLOSURES ON THE CD PROVIDED WITH THE DRIVE.**

**USING THE DRIVE INCORRECTLY CAN INJURE PEOPLE OR MANAGE THINGS.  
FULLY RESPECT THE TECHNICAL DATA AND INDICATIONS ON CONNECTION  
CONDITIONS.**

# Summary

---

## 1) Description

1.1 Description	6
1.2 General view MiniMagnum	9
1.3 Technical Data	10
1.4 Mechanical Dimension	11
1.5 Product plate and Ordering Code	12

## 2) Installation

2.1 General Advices	14
2.2 Positioning	17
2.3 Environmental conditions	18
2.4 Cables	19
2.5 Connection to ground and earth	20
2.6 Note about cable shielding	21
2.7 Base installation procedure	22
2.8 Example of base connection	23
2.9 Supply connections	24
2.10 Motor power connection	25
2.11 Regen resistance connections	26
2.12 Relè OK connection	27
2.13 Digital inputs connection	28
2.14 Analog and digital outputs connections	29
2.15 Analog inputs connections	30
2.16 Emulated encoder outputs connection	31
2.17 Pulse/Dir inputs connections	32
2.18 Feedback signals connections	33
2.19 Multidrop connection	35
2.20 Canbus connection	36
2.21 MiniMagnum™ power up	37
2.22 Motor Test	38

## 3) Diagnostic

3.1 Display	42
3.2 Alarms	43

<b>Index</b>	<b>45</b>
--------------	-----------

<b>Conformity</b>	<b>47</b>
-------------------	-----------

## Enclosures to the manual

---

On the CD provided with the drive there are the following enclosures (in pdf):

- Operative Modes Manual
- Additional Features Manual
- Speeder One Interface
- Positioner Manual
- Display and Keypad Manual
- Alarms Manual
- ModBus Manual
- CanOpen Reference Manual
- Cable Manual
- Oscilloscope Manual
- Procedures Manual (*available only on request*)

# Chapter 1

## Description

---

1.1 Description	6
1.2 General view MiniMagnum	9
1.3 Technical Data	10
1.4 Mechanical Dimension	11
1.5 Product plate and Ordering Code	12

# 1.1 Description

The **MiniMagnum™** is a digital drive capable of piloting both rotary AC brushless motors and linear motors, up to **7,5Nm**. It can be supplied by a 3-phase voltage equal to **380** or **480Vac**.

OPERATIVE MODES		
<b>SPEED CONTROL</b>	It is <b>speed piloting</b> utilising a digital reference or an analogue reference (differential or common mode).	standard
<b>TORQUE CONTROL</b>	It is <b>torque piloting</b> utilising a digital reference or an analogue reference. This function allows you to control the current from the drive.	standard
<b>POSITION CONTROL</b>	The positioner can be managed via hardware (by using the digital inputs) or via RS232 (by using the Axor's <i>Speeder One</i> interface or another ModBus Master). It supports <i>32 programmable position profiles</i> ; a <i>single task</i> or a <i>sequence of tasks</i> are permitted.  The <b>Homing Procedure</b> is implemented. It uses the signal coming from the <i>homing sensor</i> and eventually the <i>zero signal</i> of the encoder.	standard
<b>ELECTRICAL AXIS (GEARING)</b>	It is possible to pilot the drive with the quadrature signals of an emulated encoder from a Master drive or with the quadrature signals of an incremental encoder from a Master motor ( <b>Electrical Axis</b> or Gearing).	<i>optional</i>
<b>PULSE/DIRECTION</b>	It is possible to connect the drive to a <b>stepper-motor controller</b> , piloting it with the +/-Pulse and +/-Dir signals (Pulse/Dir Mode).	<i>optional</i>
<b>MULTIDROP RS232</b>	It can work in <b>Multidrop</b> , where the first drive, connected via RS232 to the Master PC, is piloted with <i>ModBus communication</i> , while the other drives are piloted with the duplication of commands using the <i>CanBus interface</i> .	<i>optional</i>
<b>RS485 INTERFACE</b>	It is possible to communicate with two or more drives by using the <b>RS485 interface</b> .	<i>optional</i> <i>AVAILABLE SOON</i>
<b>CANBUS</b>	It can be configured and controlled using <b>CanBus</b> . It supports the following <b>Can Open</b> protocols: <ul style="list-style-type: none"> <li>• part of the <b>DS301-V4.02</b></li> <li>• part of the <b>DSP402-V2.0</b></li> </ul>	<i>optional</i>
<b>Notes:</b> <ul style="list-style-type: none"> <li>• The current controller is vectorial with sampling time of 62,5µs. The velocity and position loop both work with sampling time of 250µs.</li> <li>• The current commutation is sinusoidal.</li> </ul>		
FEEDBACK		
<b>ENCODER</b>	incremental encoder signals plus hall signals	standard
<b>RESOLVER</b>	2 pole	<i>optional</i>

## 1.1 Description

<b>DIGITAL INPUTS/OUTPUTS</b>		
<b>9 programmable DIGITAL INPUTS</b>	They are programmable for: the limit switch, the holding brake, the homing and positioning procedures, the emergency stop, the reset alarm, etc.	4 standard + 5 <i>optional</i>
<b>2 programmable DIGITAL OUTPUTS</b>	They can be used to send messages from pre-programmed functions of the drive.	1 standard + 1 <i>optional</i>
<b>EMULATED ENCODER OUTPUTS</b>	There are 6 pins dedicated to <b>emulated encoder</b> with different programmed ratios (1/2, 1/4, 1/8, 1/16, 1/32, 1/64, 1/128) between output pulse/rev and encoder/resolver ones.	standard
<b>ANALOG INPUTS/OUTPUTS</b>		
<b>1 ANALOG COMMON MODE INPUT (TPRC)</b>	It is used for controlling the current from the drive.	standard
<b>1 ANALOG DIFFERENTIAL or COMMON MODE INPUTS (+/-Vref)</b>	It is used for piloting the drive with an analogue speed reference from an external controller.	standard
<b>2 programmable ANALOG OUTPUTS</b>	They allow you to visualise by the oscilloscope some of the drive's measurement values (for example: the velocity, the Iq current, etc.)	standard
<b>GENERAL FEATURES</b>		
<b>KEYPAD</b>	<b>Four buttons (UP-DW-MODE-SET)</b> allow the manual insertion of data without using a PC.	standard
<b>DISPLAY</b>	A <b>display with 3 characters</b> visualises: the inserted values, the drive's status, the alarms.	standard
<b>SPEEDER ONE SOFTWARE INTERFACE</b>	The Axor <i>Speeder One</i> interface allows you to set and manage all drive's parameters. It uses a PC connected to the drive and the communication between the drive and PC is done by a RS232 cable using the ModBUS protocol.  The software works on the following operating systems: Windows 98, Windows 2000, Windows XP.	standard

## 1.1 Description

<b>HOLDING BRAKE</b>	The drive has circuitry that allows the control of the <b>electromechanical brake integrated</b> in the motor, which can be used with <i>motor not running</i> , for blocking the motor's axis. The drive supplies the brake with <b>+24Vdc</b> . It can be <b>externally</b> managed by the user or <b>automatically</b> by the drive.	<i>optional</i>
<b>EMI FILTER</b>	The drive is equipped with an integrated <b>EMI anti-disturbance filter</b> at the 3-phase power supply input and with another EMI anti-disturbance filter at the auxiliary +24V power supply input.	standard
<b>REGEN CIRCUIT</b>		standard
<b>EXPANSION CARDS</b>	There is a slot for expansion card to implement additional features.	<i>optional</i>
<b>SAFETY</b>		
<b>SAFETY</b>	The converter is protected from short circuitry, the Max/Min Voltage, the drive I <sup>2</sup> t , the Motor I <sup>2</sup> t , etc. When there is an alarm the "Relè OK" contact opens and the motor is stopped, or a message is visualised on the display without compromising the system's functioning.	standard
<b>SAFETY ENABLE FUNCTION</b>	It is a safety function which avoids the accidental startup of the motor in the absence of 24Vdc on indicated pin.	<i>optional</i> <i>AVAILABLE</i> <i>SOON</i>
<b>BLACK-OUT DYNAMIC BRAKE FUNCTION</b>	It stops the motor when there is a black-out.	<i>optional</i> <i>AVAILABLE</i> <i>SOON</i>
<b>EQUIPMENT</b>		
a drive serie MiniMagnum™		standard
terminals: M1, M2, M4, M5, M6		
Service Manual		
a CD-ROM with <b>Speeder One</b> software interface and all enclosures to service manual		
terminals: M3, M7		<i>optional</i>
Motor inductance, 3x1.2mH, for cables over 20/25 meters in length		
an external braking resistor		
CBLS cable for motor feedback signal, encoder/resolver (meter multiple)		
CBLS power cable for motors series SuperSAX		
motors series SuperSAX		

All *optional* features have to be requested by using the proper ordering code (see "1.5 Product plate and Ordering code").

## 1.2 General view MiniMagnum

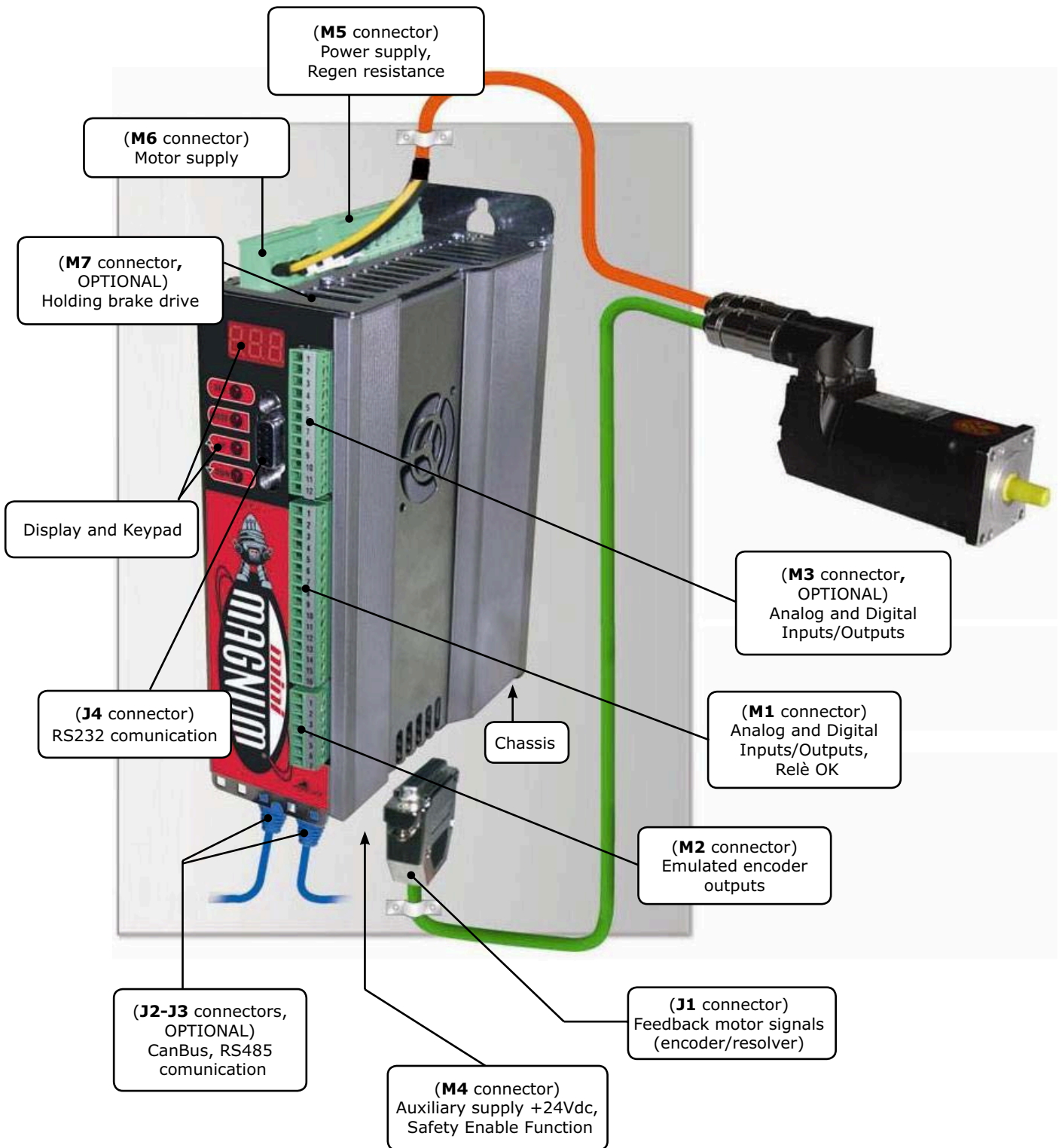

## 1.3 Technical Data

Nominal Data			
<b>Nominal Voltage</b>	Vac	Three phase: 3x480Vac +10% max, 3x380Vac -10%, 50/60Hz (Single phase permitted for setup only)	
<b>Mix/Max bus voltage</b>	Vdc	<b>380Vac</b>	<b>480Vac</b>
		400Vdc min ÷ 800Vdc max	500Vdc min ÷ 870Vdc max
<b>Auxiliary power supply (for back up)</b>	Vdc	+24Vdc (0%, +15%) - 1Adc (3Adc with brake)	
Size		1,5/3	3,5/7
<b>Nominal Current</b>	Arms	1,5	3,5
<b>Peak current for 2 sec.</b>	Arms	3	7
<b>PWM output frequency</b>	kHz	8 ÷ 16	

Control signals	
<b>Optoisolated digital inputs</b>	+24Vdc - 7mA (PLC compatible)
<b>Optoisolated digital outputs</b>	+24Vdc - 50mA (PLC compatible)
<b>Analog programmable outputs</b>	±10V (±5%)
<b>Analog common mode input (TPRC)</b>	±10V max, 20kOhm input resistance
<b>Analog differential or common input (+/-Vref)</b>	±10V max, 40kOhm input resistance
<b>Pulse/Dir digital inputs</b>	+5V, optoisolated, max. frequency 250kHz
<b>Emulated encoder outputs</b>	$V_{OH}=2.5V \text{ min} - I_{OH}=-20mA$ $V_{OL}=0.5V \text{ max} - I_{OL}=20mA$

Braking Resistance		
<b>Internal Resistance</b>	100W - 66 ohm	
<b>External Resistance</b>	500W - 66 ohm	
	1000W - 33 ohm + 33 ohm (500W)	
<b>Set point values</b>	<b>380Vac</b>	<b>480Vac</b>
	695Vdc min ÷ 735Vdc max	815Vdc min ÷ 845Vdc max

External Protections (fuses or similar)			
Size	1,5/3	3,5/7	5/10
<b>Power supply (F<sub>2</sub>)</b>	4A / 500V (Time Lag)	6A / 500V (Time Lag)	8A / 500V (Time Lag)
<b>Auxiliary power supply (F<sub>3</sub>)</b>	6A (Time Lag)		
<b>External braking resistor (F<sub>4</sub>)</b>	4A F		6A F

## 1.4 Mechanical Dimension

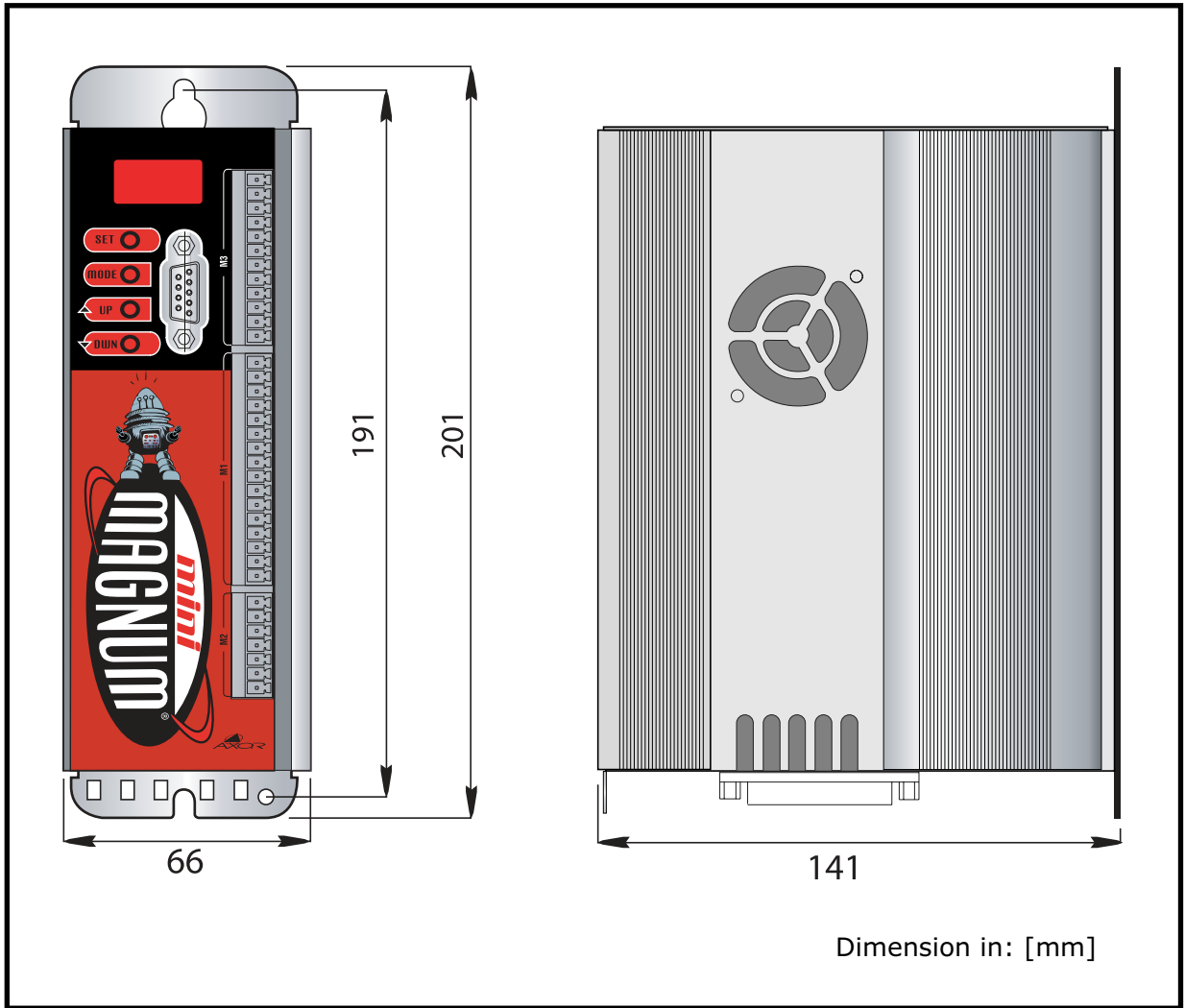

Mechanical specifications		
Drive assembly		Panel mount
External dimensions	mm	201 x 141 x 66
Weight	Kg	1,750

# 1.5 Product plate and Ordering Code

On the side of each **MiniMagnum™** there is a **product plate** like the follow:

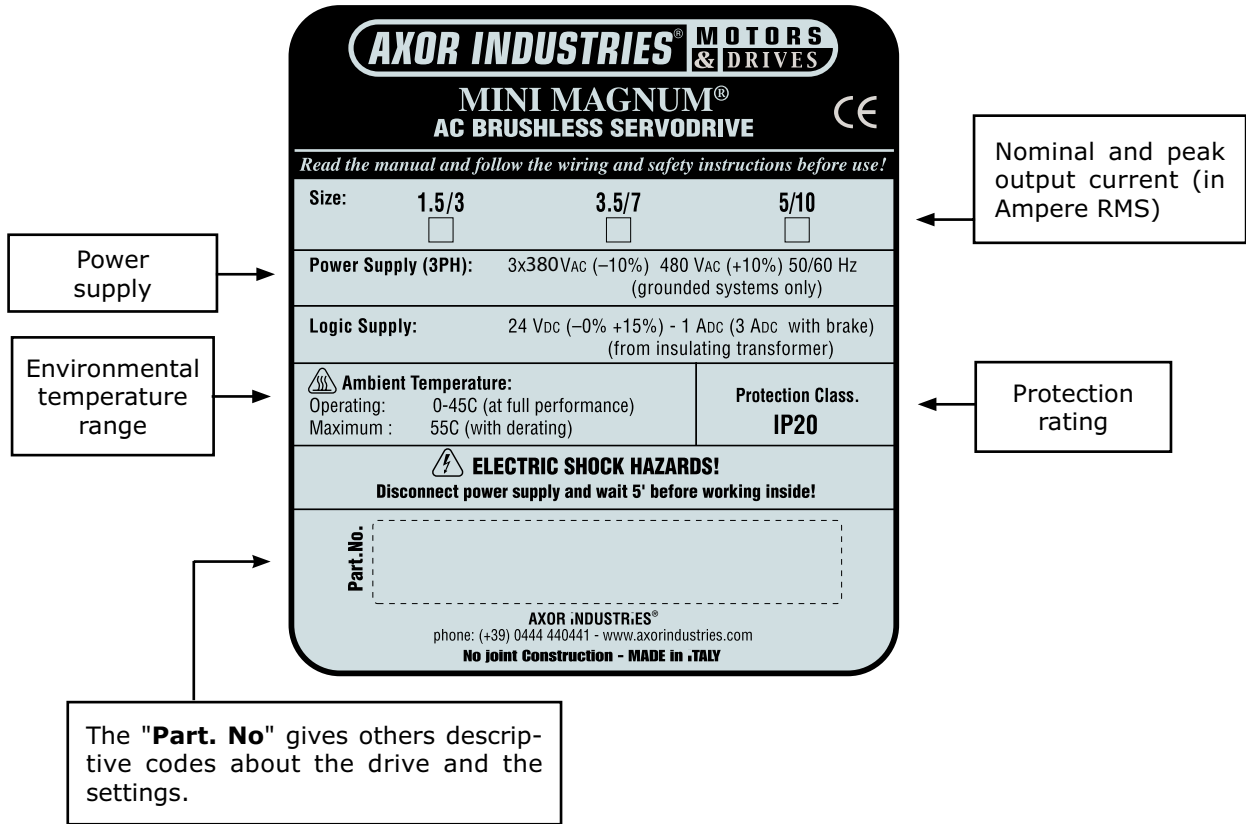

To order a digital drive serie **MiniMagnum™** refer to this **ordering code**:

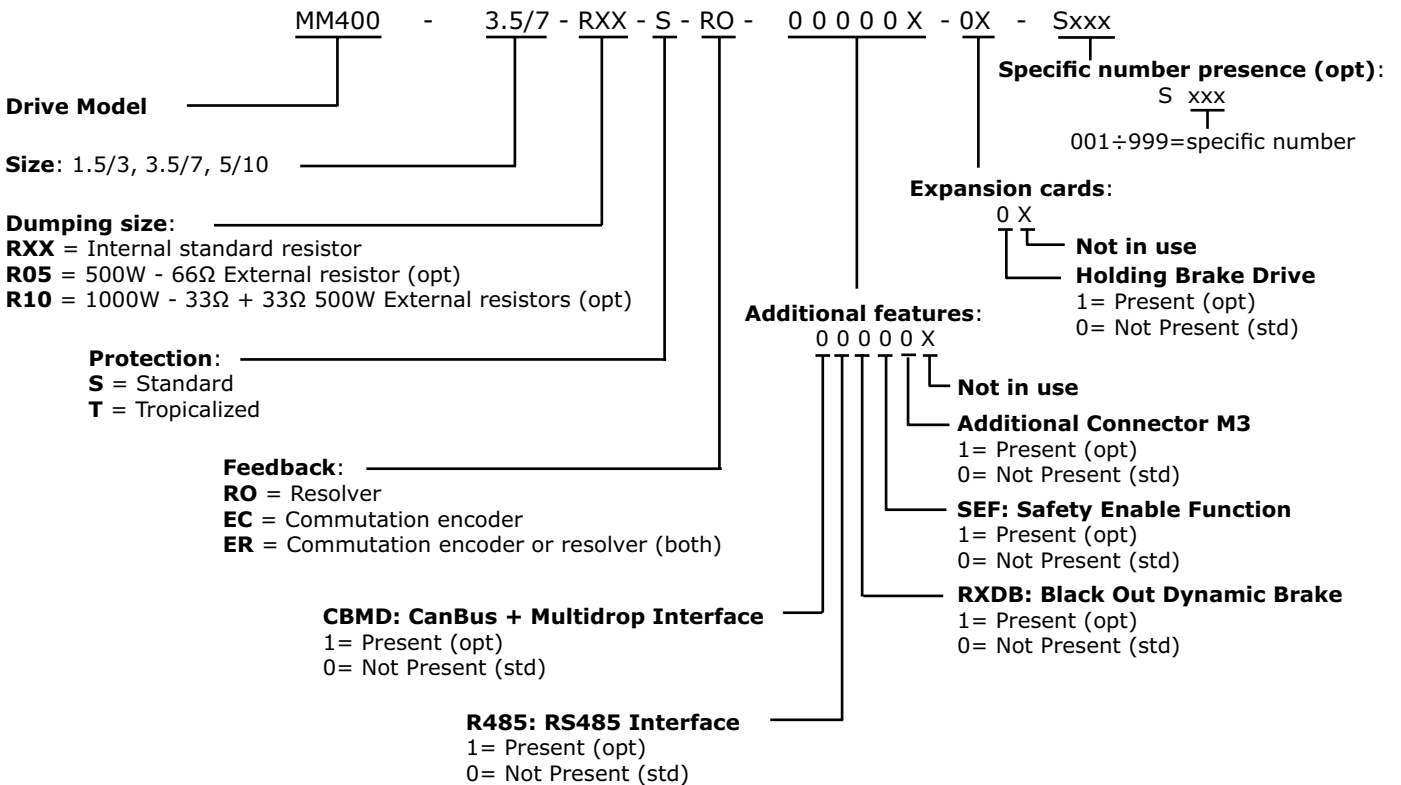

# Chapter 2

## Installation

---

2.1 General Advices	14
2.2 Positioning	17
2.3 Environmental conditions	18
2.4 Cables	19
2.5 Connection to ground and earth	20
2.6 Note about cable shielding	21
2.7 Base installation procedure	22
2.8 Example of base connection	23
2.9 Supply connections	24
2.10 Motor power connection	25
2.11 Regen resistance connections	26
2.12 Relè OK connection	27
2.13 Digital inputs connection	28
2.14 Analog and digital outputs connections	29
2.15 Analog inputs connections	30
2.16 Emulated encoder outputs connection	31
2.17 Pulse/Dir inputs connections	32
2.18 Feedback signals connections	33
2.19 Multidrop connection	35
2.20 Canbus connection	36
2.21 MiniMagnum™ power up	37
2.22 Motor Test	38

## 2.1 General Advices

---

### Transport

During the transport of the drive respect the following indications:

- the transport must be made by qualified personnel;
- avoid shocks;
- the temperature range must be between -20°C and +55°C;
- the max. humidity must be 95% (without condensation);
- The converters contains elements which are sensitive to electrostatic discharges. These elements can be damaged by careless manipulation.

Discharge static electricity from your body before touching the converter.

Avoid contact with material that insulates well (synthetic fibres, films of plastic material and so forth).

- we suggest to check the motor condition at its arrival to survey eventual damages.

### Storage

The unused drives must be storage in an environment having the following characteristics:

- temperature from -20°C to +55°C;
- max. relative humidity 95% (without condensation);
- max. time with the drive powered off (without supply connections):
  - ✓ drive having a power supply  $\geq 220\text{VAC}$   $\Rightarrow$  **1 year**
  - ✓ drive having a power supply  $\leq 145\text{VAC}$  (200VDC)  $\Rightarrow$  **2 years**

After this time, before enable the drive, it is necessary activate the capacitors following this procedure: remove all electrical connections, then supply the input terminals of the supply with the main voltage (three phase or single phase) for 30 minutes.

In details:

- for the drive having a power supply equal to 380VAC: power it by using a single phase (or three phase) supply equal to 220VAC;
- for the drive having a power supply equal to 220VAC: power it by using a single phase (or three phase) supply equal to 110÷130VAC.

In order to avoid this procedure, we suggest to power on the drive with its rated voltage for 30 minutes, before the max. time is reached.

### Maintenance

The drives does not need maintenance.

Otherwise:

- if the casing is dirty: clean it with isopropanol or similar;
- if the drive is dirty: the cleaning is reserved to the producer;
- if the fans are dirty: clean them by using a dry brush.

### Disposal

The disposal should be carried out by a certified company.

## 2.1 General Advices

---

### Security standard

- **This manual is exclusively addressed to technical personnel with the following requirements:**

- **Technician with knowledge on movimentation of elements sensitive to electrostatic discharges (for the transport).**
- **Technician with appropriate technical training and with vast knowledge on electrotechnics/drive technical field (for the installation and operation of servodrives).**

**Using the drive incorrectly can injure people or damage things. Fully respect the technical data and indications on connection conditions.**



- As well as the points described in this manual, current regulations regarding safety and accident prevention must be followed in order to prevent accidents and residual risks.

The installer must be familiar with and observe the following norms and directives:

- IEC 364 and CENELEC HD 384 or DIN VDE 0100;
- IEC-Report 664 or DIN VDE 0110;
- national accident prevention dispositions or BGV A2.

- The user must analyse possible machine risks and take the necessary measures to avoid injuries to people and damage to things because of unpredictable movements.

- The converters contains elements which are sensitive to electrostatic discharges. These elements can be damaged by careless manipulation.

Discharge static electricity from your body before touching the converter.

Avoid contact with material that insulates well (synthetic fibres, films of plastic material and so forth).

- During operation, the converter surface can become hot. Protect the user from accidental contact and keep the indicated distances from all objects.

- Never loosen electrical connections while the servoamplifiers are being powered.

The appropriate terminals of the drive must always be connected to earth as instructed in this manual. After having disconnected the converters from the supply current, always wait at least 5 minutes before touching the powered components (e.g. contacts) or loosening connections.

- Switch off the converter and wait at least 5 minutes before opening it. Remove the fuses or switch off the main switch before removing the drive. When opening, place the converter on a surface that does not belong to the electrical panel.

- The residual charges in the capacitors can remain at a dangerous level for up to 5 minutes after disconnection from the mains. Measure the voltage at the intermediate circuit (+AT/-AT) and wait until it is below 15V.

- The command and power connections can still hold current even when the motor has stopped.

- The **MiniMagnum™** is equipped with electronic protections that deactivate it in case of irregularities. The motor, as a result, is not controlled and can stop or go into neutral (for a time determined by the type of system).

- During installation, avoid letting any residue with metallic components fall inside the drive.

## 2.1 General Advices

---

- Protect the converter from excessive mechanical vibrations in the electrical box.
- Check that the main supply and the nominal current are coherent with the rating of the drive. Be sure that the voltage between the connectors L1-L2-L3 is not greater than 10% of the nominal values. An excessively high voltage causes the breakdown of the load circuitry and of the drive.
- The **MiniMagnum™** is equipped with an integrated **EMI anti-disturbance filter** at the 3-phase power supply input and with another EMI anti-disturbance filter at the auxiliary +24V power supply input. Being implicit to filter operation the deviation towards earth or mass of the undesired frequencies, ensure that these devices can produce leakage currents towards earth, which are measurable in milliAmps. Please remember that "leakage currents" must be considered when settings differential devices in order to avoid useless interventions.  
For safety reasons connect the prepared terminal to earth before powering the drive. Incorrect connections make filter operation unreliable.

## 2.2 Positioning

The **MiniMagnum™** is made to be fixed vertically to the **bottom of the electrical box** in order to guarantee reliable cooling, respecting the following distances:

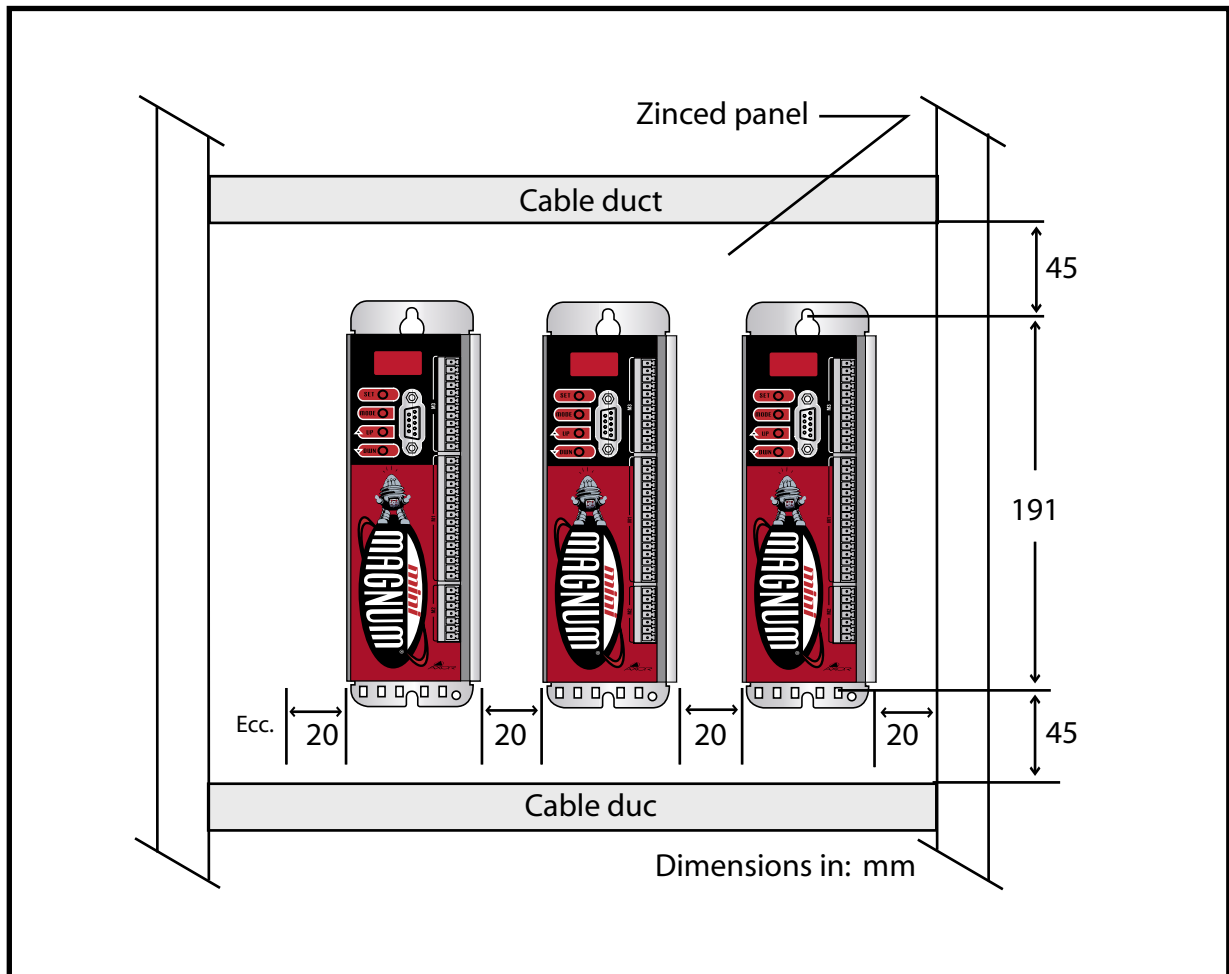

**Note:** Arrange the power components (converters, main's filters, resistors, terminals, ... ) in bins of the electrical panel different from those reserved to the command or control systems (PLC, PC, CNC, regulators, ...). This improves the level of immunity to interference of the system.

## 2.3 Environmental conditions

---

During the storage and the installation respect the followings environmental conditions:

<b>Condizioni ambientali</b>	
<b>Storage temperature</b>	-20°C...+55°C
<b>Working environmental temperature</b>	From 0°C to +45° C (no derating). From +45°C to +55°C the drive must be derated 2.5%/°C in reference to nominal and peak current.
<b>Humidity</b>	From 10% to 85%
<b>Altitude</b>	Up to 1000m without restriction. From 1000 to 2500m of altitude the converter must be derated in the output current of 1.5% every 100m.
<b>Enclosure protection</b>	IP20
<b>Pollution level</b>	LEVEL 2 (Norm EN60204/EN50178) The drives are designed to be utilized in an electrical box protected against the infiltration of polluting agents such as water, oil, conductive dust and others.

### Notes:

- The electrical box must have suitably **filtered air vents**.  
Leave the necessary space both above and below the converters.
- Periodically check drive case and fans for excess dust or dirt, that could interfere with the correct dissipation of the drive.

## 2.4 Cables

The following table illustrates the technical characteristics of all cables:

Cables (as norm EN60204)		
Type	Section	Notes
for the Main Supply	1.5mm <sup>2</sup> /15AWG	<b>Always insert a power relay or a thermal magnet on every phase of the products power supply.</b>
for the Auxiliary Supply	1.5mm <sup>2</sup> /15AWG	Connect the 0V of the auxiliary supply to the ground bar.
for the Motor's Brake	0.75mm <sup>2</sup>	It must shielded.
for the Motor's Power	1.5mm <sup>2</sup> /15AWG	It must be shielded. It must have a capacity of ≤150pF/m. In the configuration without filter, the cable can reach a maximum length of 20/25m. If the length exceeds 20/25m, insert an Axor <b>3x1.2mH</b> filter.
for the Control signals and I/O signals from PLC/CNC	0.5mm <sup>2</sup> /20AWG	See "2.6 Note about cable shielding"
for the Encoder signals	0.25-0.35mm <sup>2</sup> / 22-24AWG	It must be shielded.
for the Resolver signals	0.25-0.35mm <sup>2</sup> / 22-24AWG	It must have a capacity less than 120pF/m.
for external resistor	1.5mm <sup>2</sup> /15AWG	
for the RS232 communication	0.22mm <sup>2</sup> /24AWG or 0.34mm <sup>2</sup> /22AWG	The length of the cable must be equal to or less than 2.5m. It must be connected when the main supply and the auxiliary supply are both powered off. It must have a capacity less than 160pF/m.
for the CanBus communication	0.25mm <sup>2</sup> /0.34mm <sup>2</sup>	Cable capacitance: max 60 nF/km. Impedance characteristics : 100...120Ω. Lead resistance (loop): 159,8 Ω/km The length depends upon the transmission speed: • 1000kbit/s ⇒20m max; • 500kbit/s ⇒70m max; • 250kbit/s ⇒115m max.
<p><b>Note:</b></p> <ul style="list-style-type: none"> <li>• Avoid crossing, overlapping and twisting cables together. If it is absolutely necessary to cross them, do so at 90°.</li> <li>• On request Axor provides motor signal cables series <i>encoder or resolver</i> for motors series <i>Super-SAX</i>.</li> </ul>		

## 2.5 Connection to ground and earth

Make sure that the servodrive and the motor are connected to earth in accordance with the current norms.

This connection must be done by using a copper bar, mounted on insulating supports:

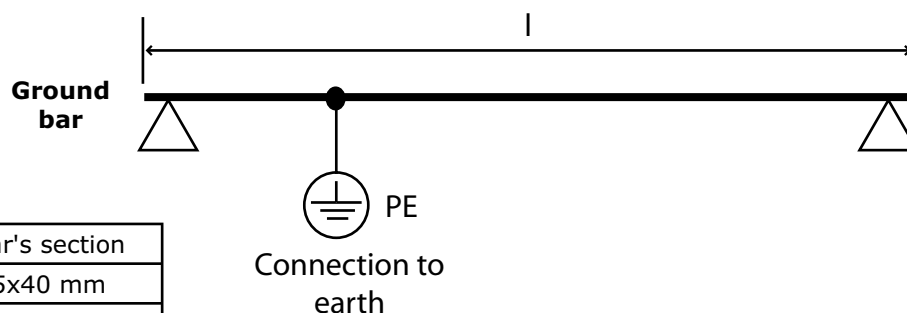

l	Bar's section
0,5 ...1 m	5x40 mm
1 ... 2 m	5x50 mm

then follow these indications:

1. Connect to the ground bar:

- ✓ the **earth power terminal of the drives**;
- ✓ the **CHASSIS** of all drives;
- ✓ the **DGT-IN RTN** pin of the digital inputs for each drive;
- ✓ the **0V of the auxiliary supply**;
- ✓ the **internal zero voltage of the CNC**;
- ✓ the **earth terminals of the PLC/CNC frames**;

2. Connect the **ground bar** to the zinced panel of the drive by using a screw, then connect that screw to **earth**.

3. Connect earth to the **motor's carcass**.

Symbol	Description
	It suggests a conductive connection as much as possible to the chassis, or the heat-sink, or the mounting panel of the electrical box.
	It refers to the earth connection.
	It refers to the connection of the shield to the drive's carcass as illustrated on page 21.
	It refers to the connection of the shield to the connector's metal ring.

## 2.6 Note about cable shielding

### Control signal cables

The conductor of the analogic signal must be twisted and shielded, and the shield must be connected to ground as illustrated below:

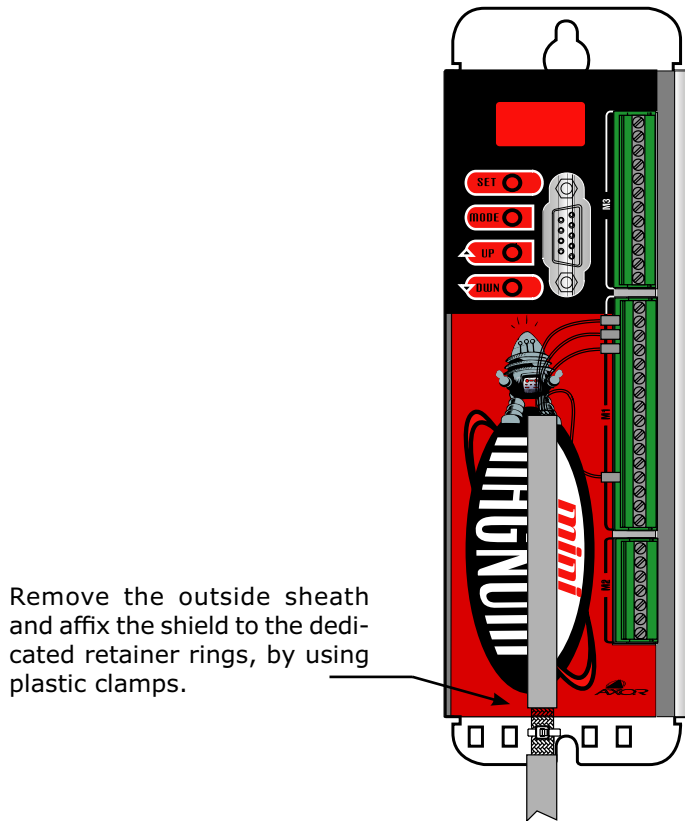

#### Note:

- To reduce the capacitive and inductive coupling, these cables must be run keeping a distance of more than 30cm from the power cables (10 cm if they are shielded).
- If it is absolutely necessary to cross the control cables with the I/O's, do so at 90°, in order to reduce the effect of the magnetic fields.

### Motor cables

The shield of the motor cable (power and signal cables) are connected as follows:

- *drive side* (20:50cm) ⇒ remove the outside sheath and fix shield to the zinced panel, by using a u-clamp:

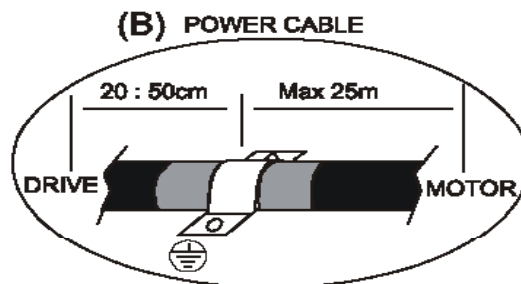

- *motor side* ⇒ The shield is internally connected to the metal ring of the motor connector, thus to earth through the motor's carcass.

## 2.7 Base installation procedure

---



**This procedure must be done only by qualified personnel which are familiar with drives. If you need more information contact Axor.**

- a) **Power off** all the supplies of the electrical box.
- b) Verify:
  - ✓ the **drive-motor coupling** ⇒ the stall current ( $I_0$ ) of the motor should be equal to/or greater than the nominal output current of the drive;
  - ✓ the **positioning** of the drive into the electrical box;
  - ✓ the **pollution level** and the **ventilation**;
  - ✓ the **connection to earth** of the electrical box where the drive is installed (see "2.5 Connection to ground and earth").
- c) Execute the wiring following this order, avoiding that wiring's pieces, cables, wires, screws, conductive objects, etc. do not enter into the drive through its slits:
  - 1- First connect **earth**.
  - 2- Connect the **cables for the motor's power** (U, V, W) and the **filter 3x1.2mH**, if the cable length is greater than 20/25m.
  - 3- Connect the **earth of the motor's power** (PE) and, if necessary, connect the cables of the **electromechanical brake**.
  - 4- Connect the **external shield** of the motor's cable: it must be shielded utilising a u-clamp to the zinc panel of the electrical box (see "2.6 Note about cable shielding").
  - 5- If an **external braking resistor** is used, connect it between pins +R and -R by using a cable as short as possible. If the cable length is greater than 20/30 cm, the cable must be twisted and shielded, besides the shield must be connected to ground on both ends utilising u-clamps to the zinc panel of the electrical box.
  - 6- Connect the motor's feedback cable to the drive's **J1** connector
  - 7- Connect the **main power supply cable** (L1-L2-L3) and the **earth cable** (PE).  
**Always insert a power relay or a thermal magnet on every phase of the products power supply.**
  - 8- Connect the **auxiliary supply cable** (+24V).  
Use an external power supply, that must be stabilized and galvanically isolated from the main supply.
  - 9- Connect the PC to the drive utilising the **RS232** cable.
  - 10- Supply the drive with the **auxiliary supply** and then **main supply** following the *procedure* illustrated at the end of the chapter.
  - 11- Open the *Speeder One* interface.
  - 12- Execute the tests on the drive and the motor.

In the following page there is an *example of a basic connection*.

## 2.8 Example of base connection

Example of BASE connection:

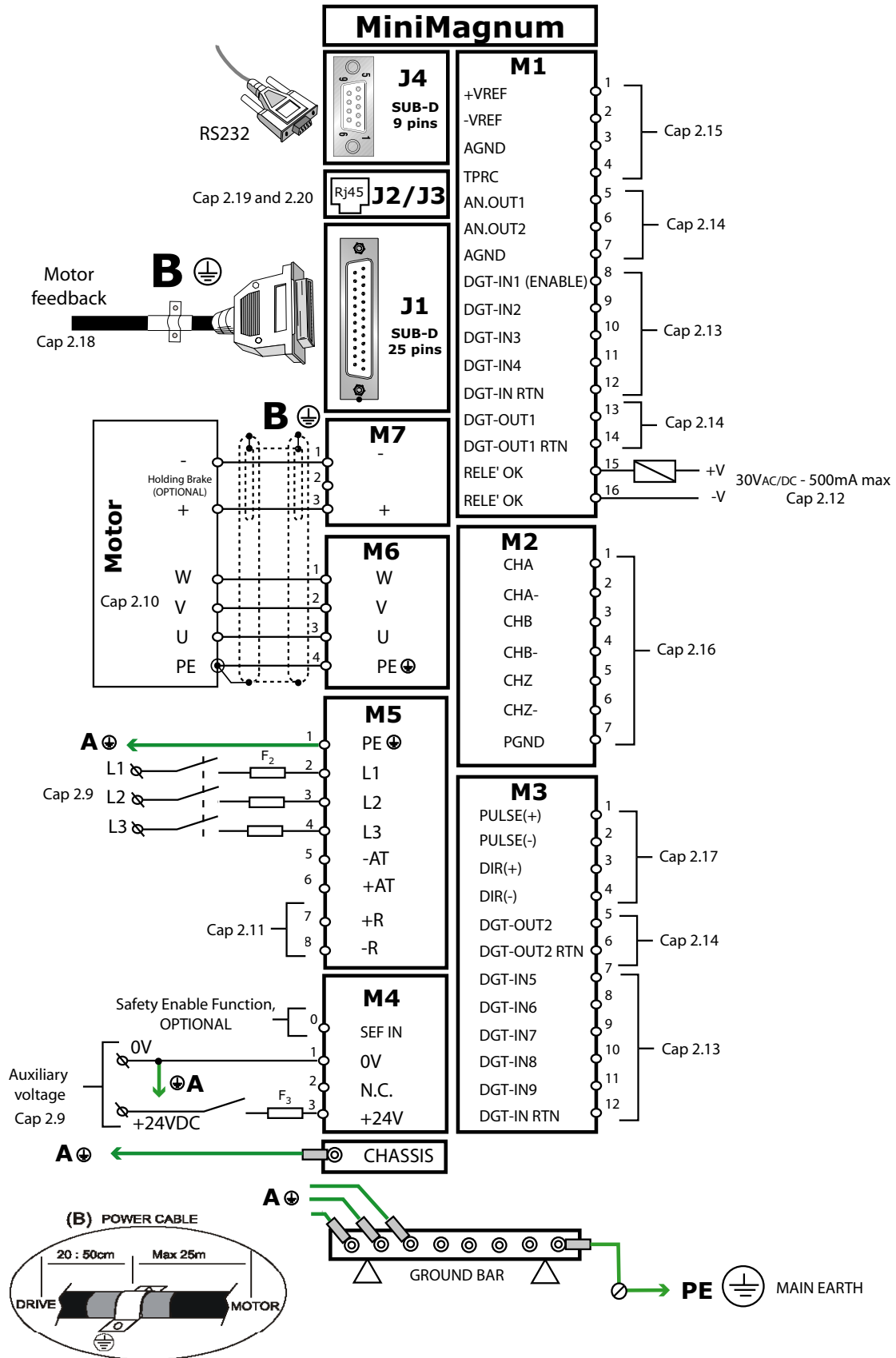

## 2.9 Supply connections

### AUXILIARY SUPPLY +24Vdc

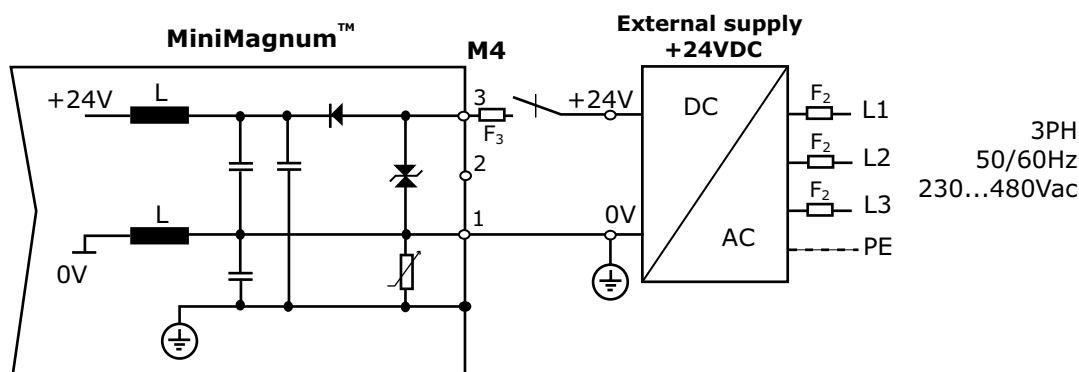

#### Note:

- Accepted voltage: **+24VDC** (0%/+15%);
- current required for the external supply: **3A** (motor with brake);
- current required for the external supply: **1A** (motor without brake);
- we suggest to insert the **F<sub>3</sub>** (6A T) fuse;
- Remember to connect the 0V of the external supply to the ground bar.

### POWER SUPPLY

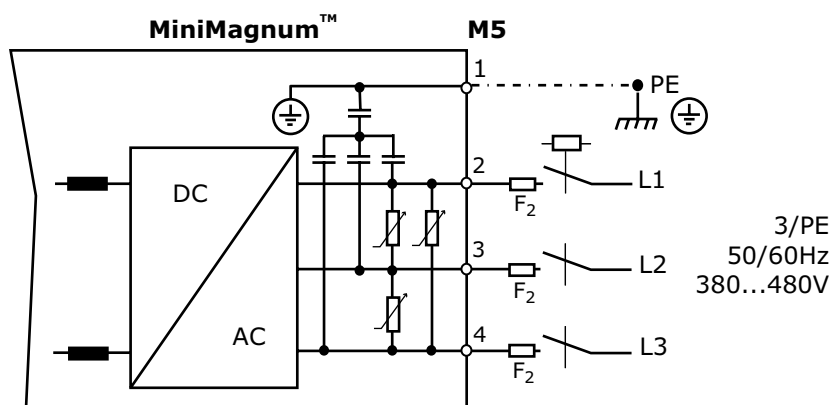

#### Note:

- **Always insert a power relay or a thermal magnet on every phase of the products power supply.**

• If a power supply between 380V and 480V is utilized and ground protection is not present, or there is an asymmetrical grounding system, an **isolation transformer** is required. The **nominal power of the transformer** is calculated by adding the various wattage of each motor:

$$P_t = P_n + P_n + P_n + \dots$$

$P_t$  = nominal power of the transformer (VA)

$P_n$  = nominal power of each motor (VA), which can be calculated in this way:

$$P_n = n \times C_n / 9,55$$

$P_n$  = nominal motor power (W)

$n$  = motor speed (rpm)

$C_n$  = motor nominal torque (Nm)

## 2.10 Motor power connection

### MOTOR POWER + MOTOR HOLDING BRAKE

#### WITHOUT brake

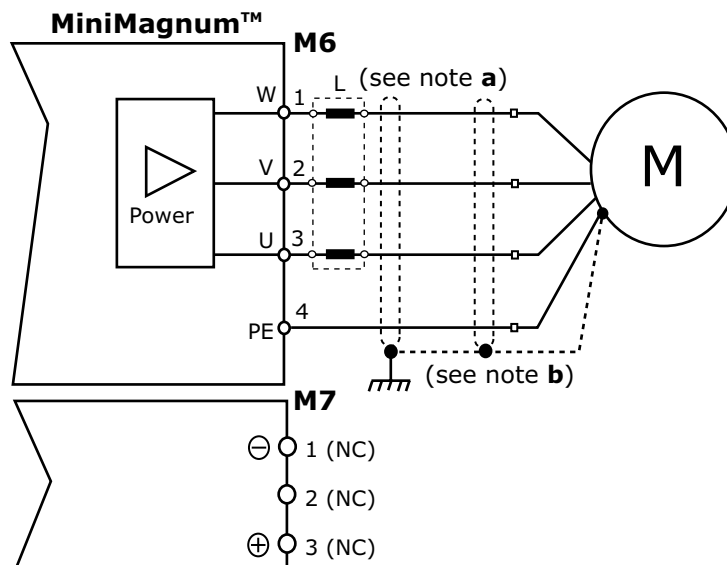

#### WITH brake

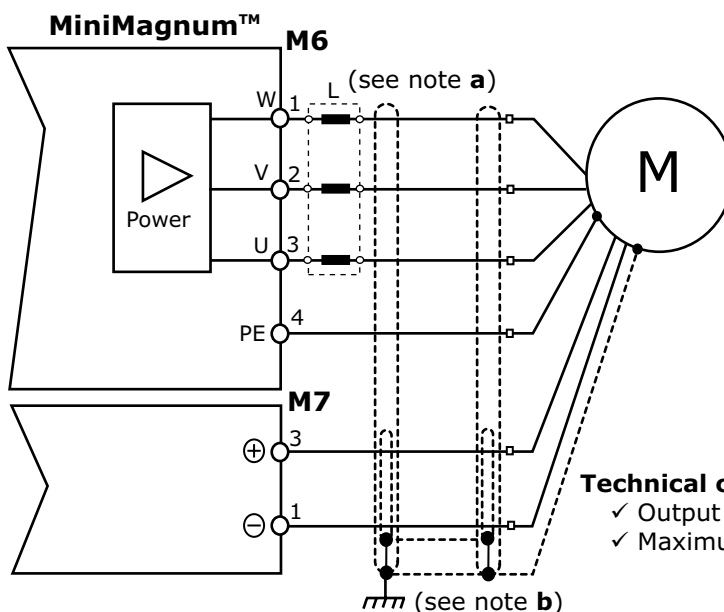

**OPTIONAL**

#### Technical characteristics of brake outputs:

- ✓ Output Voltage: **+24VDC** [0%, +15%].
- ✓ Maximum available current: **3A**.

#### Note:

**a-** Use **3x1.2mH - 20Arms** filter series for connections with cables longer than 20/25 meters.

**b-** The **earth connection** of the power cable's shield must be made on the zinc-coated panel (using a u-clamp) near the drive (20-50cm). Motor side: the shield is connected to connector's metal ring, so it is connected to ground through motor's carcass.

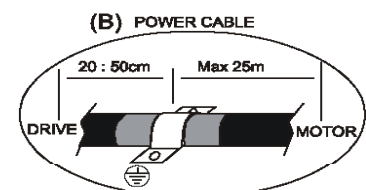

## 2.11 Regen resistance connections

### REGEN RESISTANCE connection

#### INTERNAL resistance

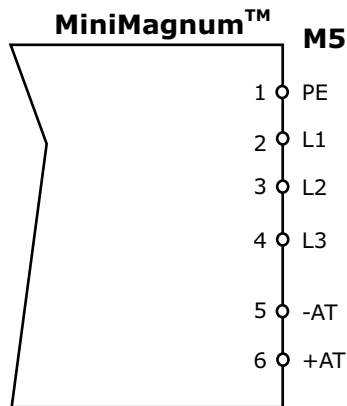

The value of internal resistance is **66 ohm - 100W**.  
It is not necessary any connection.

#### EXTERNAL resistance

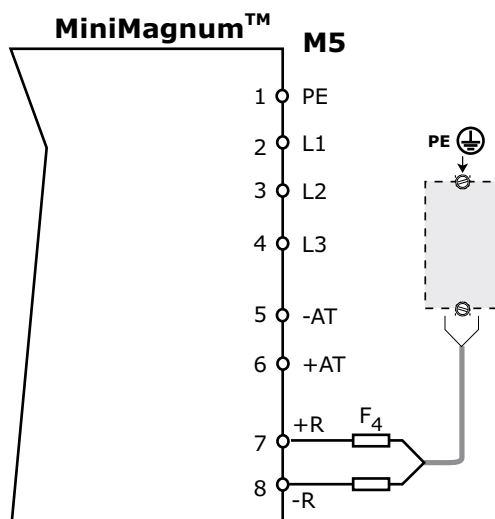

#### OPTIONAL

It is possible to use:

- one external resistance: **66 ohm - 500W**; or:
- two external resistances: **33 + 33 ohm (500W)**.

The cable must be as short as possible.  
The resistances must be connected to the zinc panel utilising two screws.  
If the cable length is greater than 20/30cm, it must be twisted and shielded.  
The shield must be connected to ground on both ends, utilising u-clamps to the zinc panel of the electrical box.

#### Notes:

- The temperature of the zinc panel of the electrical box can be higher than 200°C.
- Do not mount the resistor on surfaces which can be damaged by heat.
- If the resistors are mounted externally, protect them.
- Respect the distances and shieldings illustrated in Fig.1.
- External regen resistance has dimensions illustrated in Fig.2.

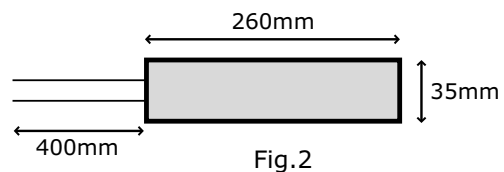
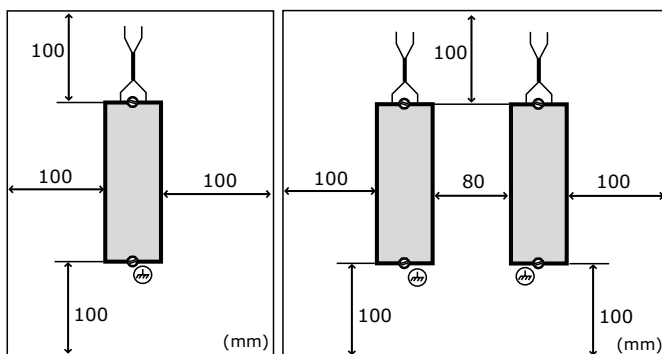

Fig.1

Fig.2

## 2.12 Relè OK connection

---

### **RELE' OK connection**

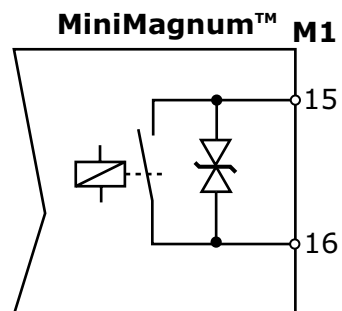

It is normally open when the drive is not supplied;  
it is normally closed when the drive is supplied and  
it has not active alarms.

30V<sub>AC/DC</sub> - 500mA max

## 2.13 Digital inputs connection

### **DIGITAL INPUTS connection**

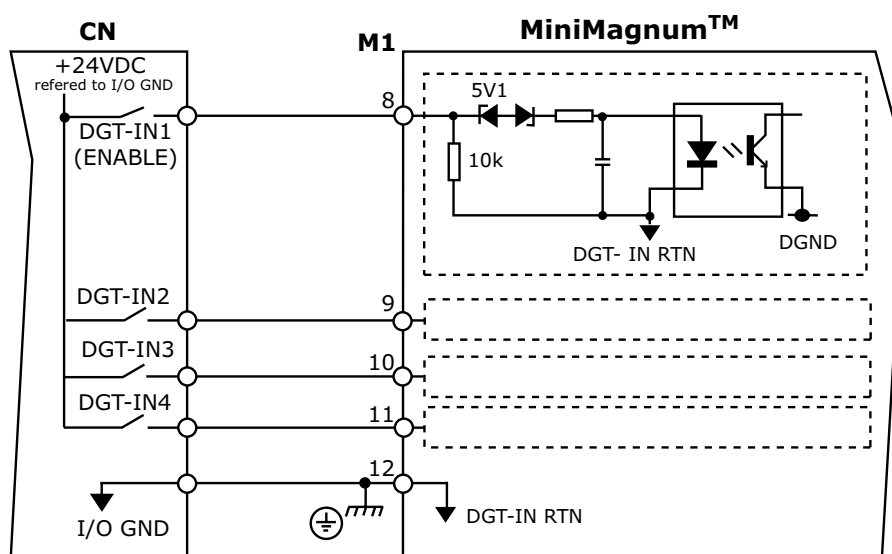

#### **Note:**

- The enable signal should be **+24VDC-7mA** (PLC compatible). The enable range is between **+14V Min** and **+30V Max**.
- The **M1-8 terminal (DGT-IN1 (ENABLE))** is used only as the drive's enable. If M1-8 is HIGH (+24VDC) the drive is enabled (without active alarms and if start up sequence, illustrated on paragraph 2.21, is respected); if M1-8 is LOW (0V), the motor is without torque.  
ATTENTION: THE DRIVE'S ENABLE/DISABLE, BY USING THE ENABLE INPUT, IS NOT CONSIDERED A SECURITY FUNCTION.
- The **M1-9, M1-10, M1-11** *programmable* inputs can be used to activate pre-programmed functions of the drive (for example: limit switch , electromechanical brake, homing and positioning procedures, emergency stop, etc.).  
For a detailed description of the pre-programmed functions see enclosure "**Speeder One Interface**", "**Additional Features Manual**" and "**Positioner Manual**" on the CD provided with the drive.  
If there is the **M3** connector (OPTIONAL), it provides five additional digital inputs and one of them is programmable.
- Connect pin **M1-12 (DGT-IN RTN)** to the ground bar of the system.

## 2.14 Analog and digital outputs connections

### DIGITAL OUTPUT Connection (example)

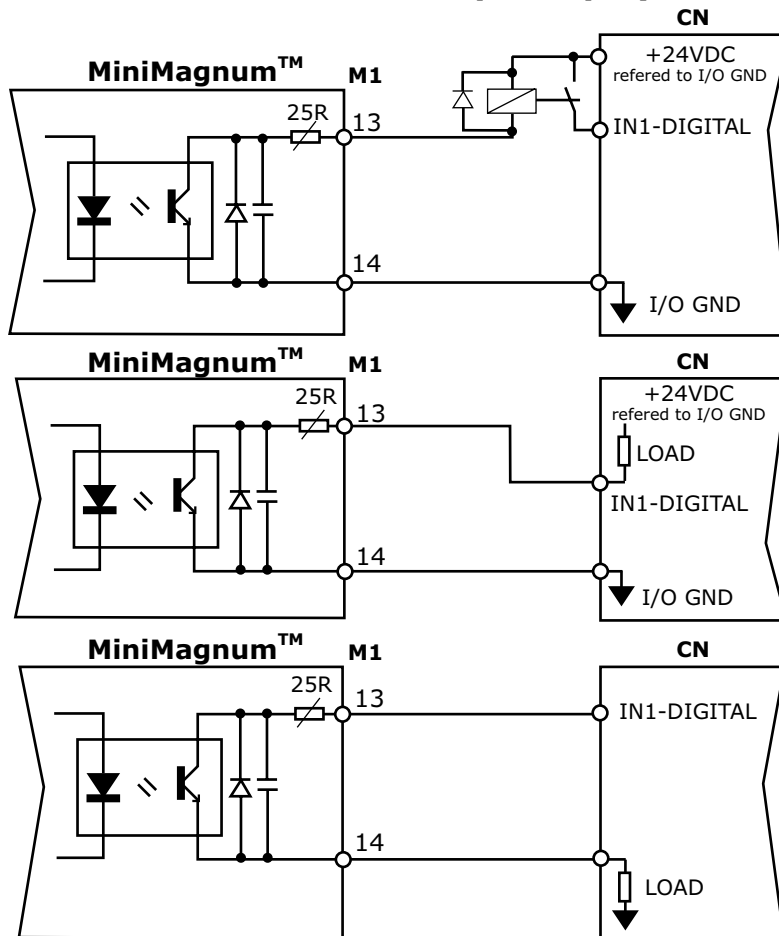

Max. load for each output: 50[mA].

Always use a relay with a diode in parallel.

This digital output can be used to send messages from the pre-programmed function of the drive. For a detailed description of the pre-programmed functions see enclosure "**Speeder One Interface**" on the CD provided with the drive. If there is the **M3** connector (OPTIONAL), it provides an additional digital output.

### ANALOG OUTPUTS Connections

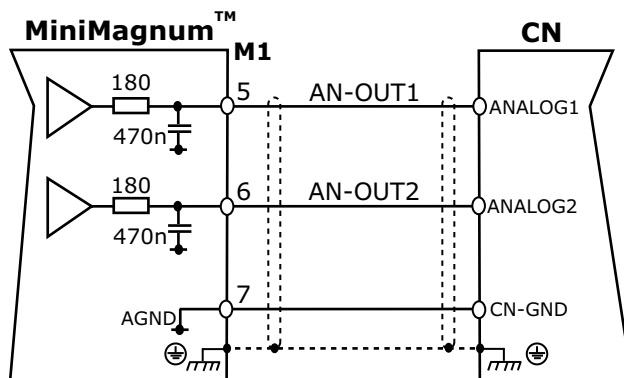

They permit visualisation by oscilloscope of some of the drive's measurement values.

The two outputs furnish **+/-10Volt** as the low scale setting refers to.

They can be set by the *Speeder One* interface.

**Note:** We suggest to connect the shield on both sides: drive side follow the indications illustrated on paragraph 2.6.

## 2.15 Analog inputs connections

### **ANALOG DIFFERENTIAL OR COMMON MODE INPUT (+/-Vref and TPRC) connection**

#### **DIFFERENTIAL MODE (+/-Vref)**

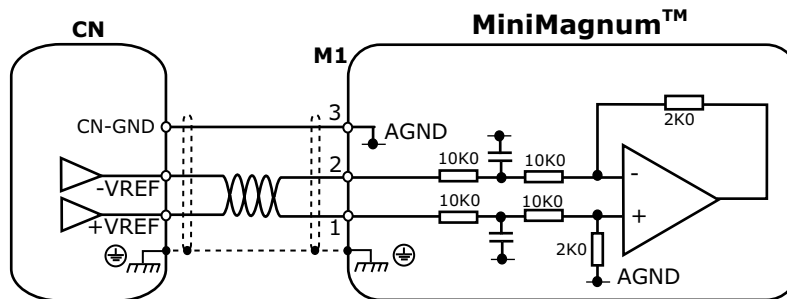

#### **COMMON MODE (+/-Vref)**

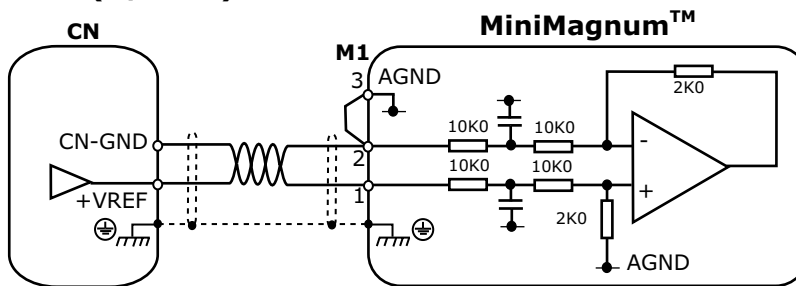

The **technical characteristics** of these inputs are as follows:

- ✓ Voltage: **±10V** Max.
- ✓ Input impedance: **40k ohm**.

To change the sense of rotation, apply the positive voltage reference to **M1-2**, or change the **Rotary Direction** parameter in the **Speed** window (from **Positive** to **Negative**).

**Note:** We suggest connecting the shield on both sides: drive side, follow the indications illustrated on paragraph 2.6.

#### **COMMON MODE (TPRC)**

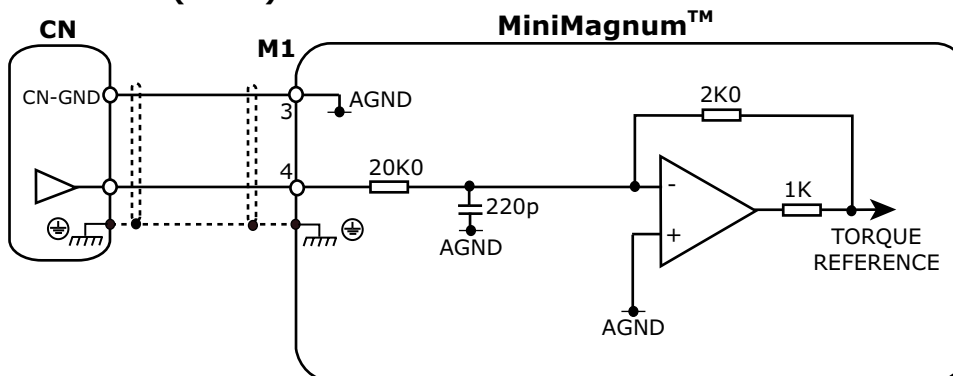

The **technical characteristics** of TPRC input are as follows:

- ✓ Voltage: **±10V** Max.
- ✓ Input impedance: **20k ohm**.

**Note:** We suggest connecting the shield on both sides: drive side, follow the indications illustrated on paragraph 2.6.

## 2.16 Emulated encoder outputs connection

### EMULATED ENCODER OUTPUTS connection

#### LINE RECEIVER CN inputs

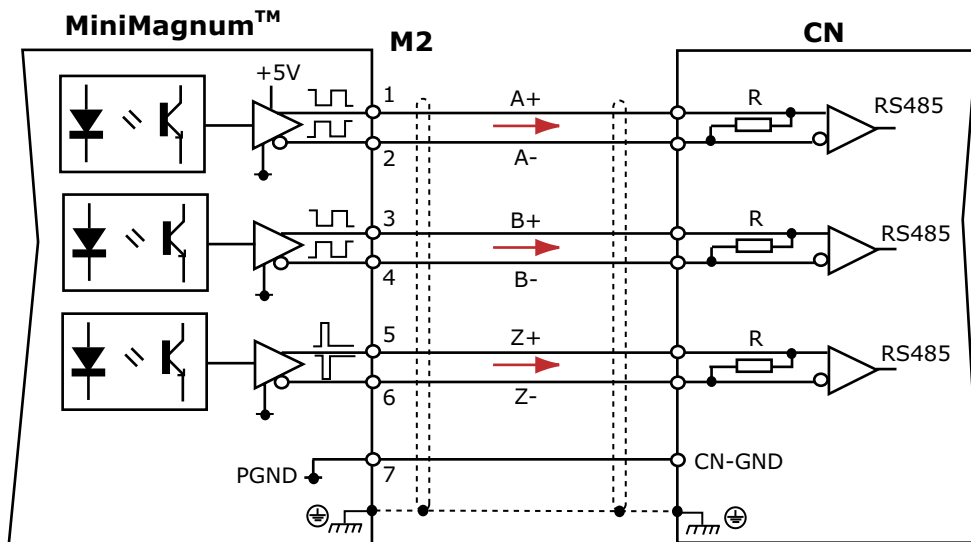

#### COMMON MODE CN inputs

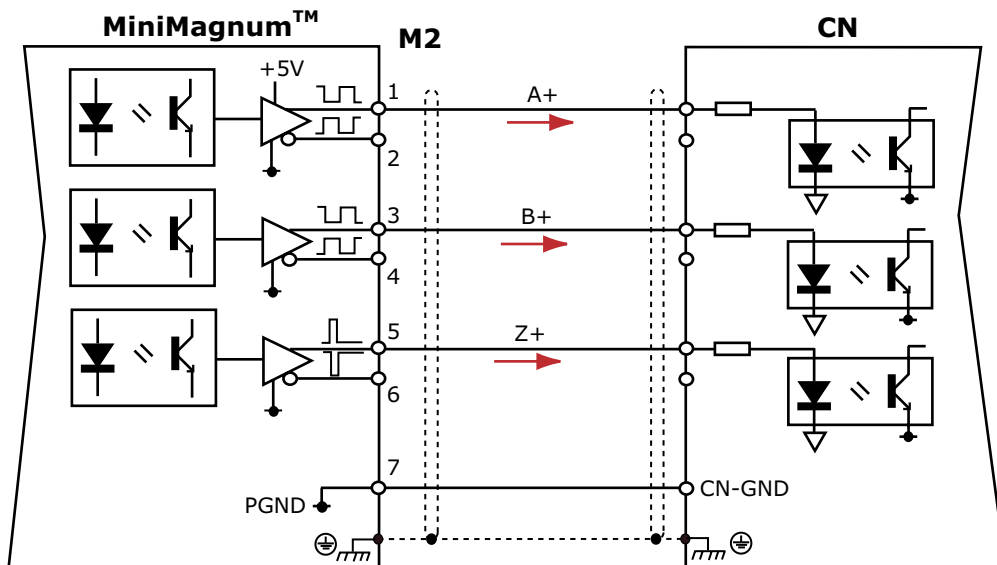

**Note:** We suggest connecting the shield on both sides: drive side, follow the indications illustrated on paragraph 2.6.

## 2.17 Pulse/Dir inputs connections

### **PULSE/DIRECTION MODE connection**

**OPTIONAL**

Logical signal 0/+5V

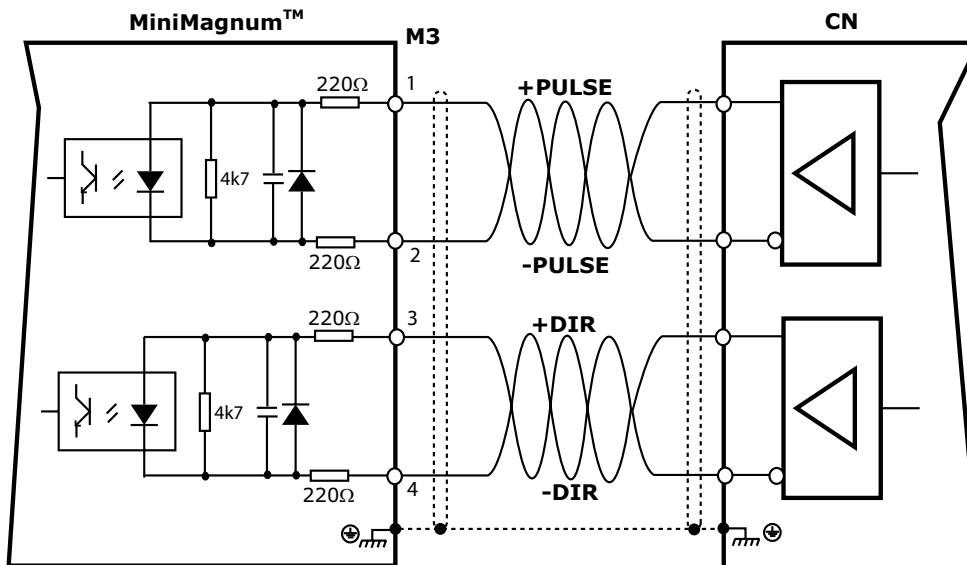

**Note:** We suggest connecting the shield on both sides: drive side, follow the indications illustrated on paragraph 2.6.

### **ELECTRICAL AXIS (GEARING) Connection**

**OPTIONAL**

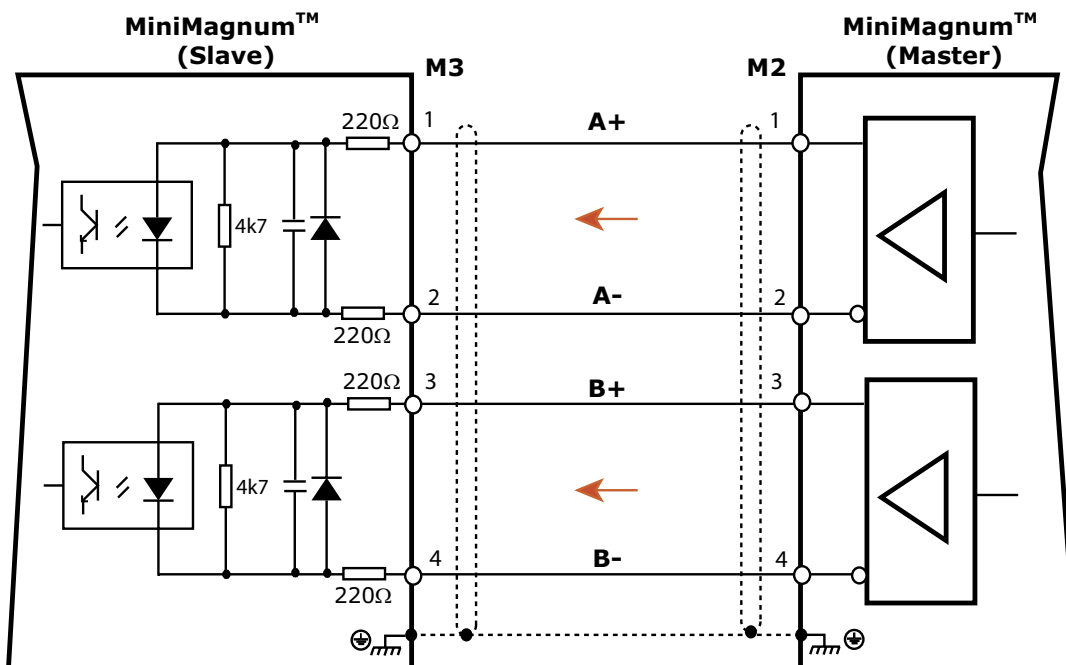

**Note:** We suggest connecting the shield on both sides: drive side, follow the indications illustrated on paragraph 2.6.

## 2.18 Feedback signals connections

### ENCODER FEEDBACK connection

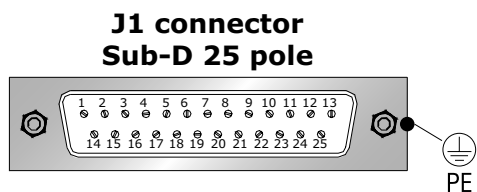
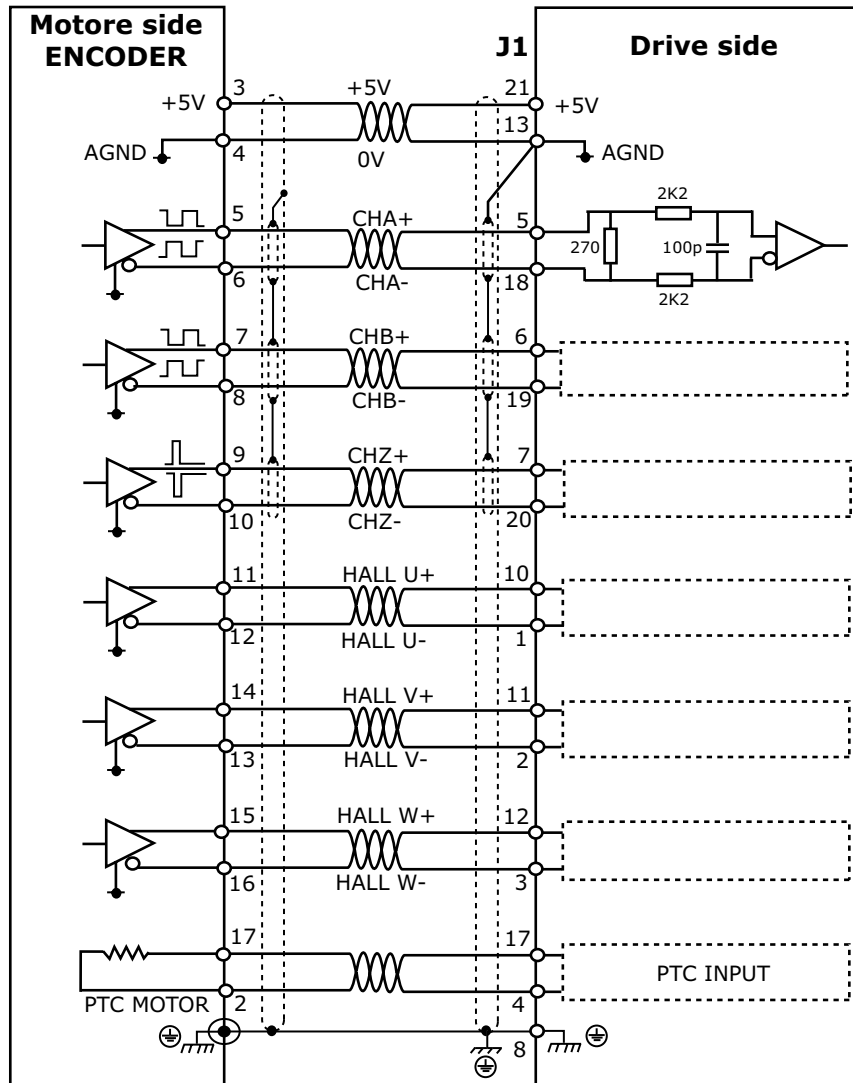

**If the motor has not the thermal protection (PTC MOTOR) you should bridge pins 4 and 17 on the "J1, Sub-D 25 pole" connector of the drive.**

**Note:** The **ground connection** of the external shield must be made on the zinc-coated panel (using a u-clamp) near the drive (20-50cm).  
Motor side: the shield is connected to connector's metal ring.

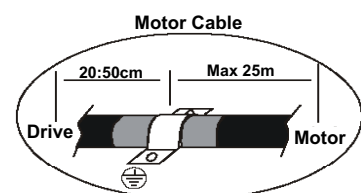

## 2.18 Feedback signals connections

### RESOLVER FEEDBACK connection

**OPTIONAL**

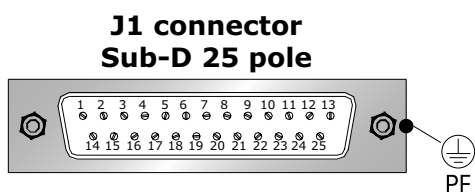
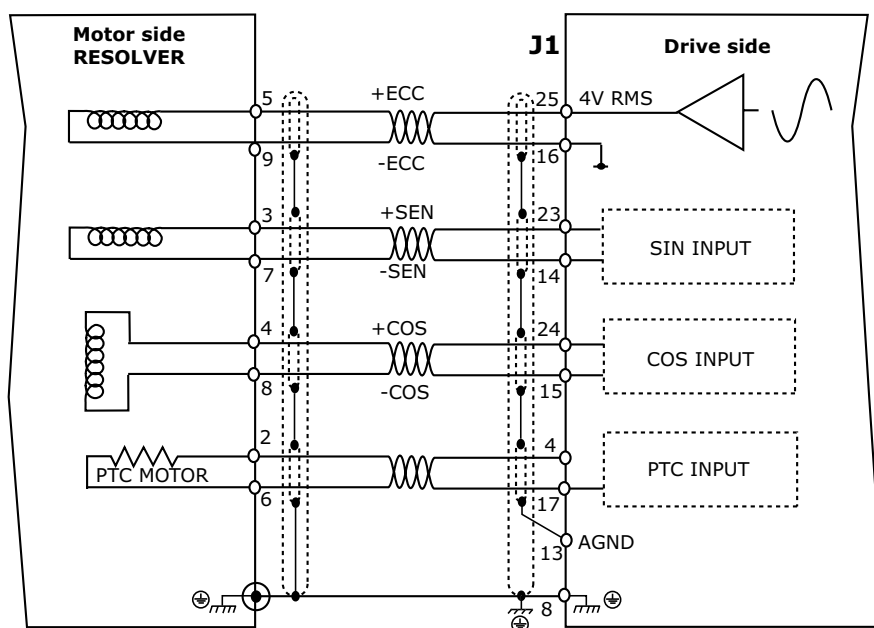

**If the motor does not have thermal protection (PTC MOTOR) you should bridge pins 4 and 17 on the "J1, Sub-D 25 pole" connector of the drive.**

**Note:** The **ground connection** of the external shield must be made on the zinc-coated panel (using a u-clip) near the drive (20-50cm).

Motor side: the shield is connected to connector's metal ring.

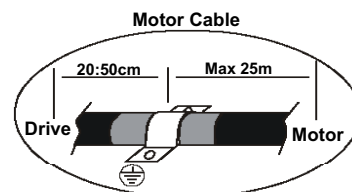

## 2.19 Multidrop connection

### MULTIDROP connection

**OPTIONAL**

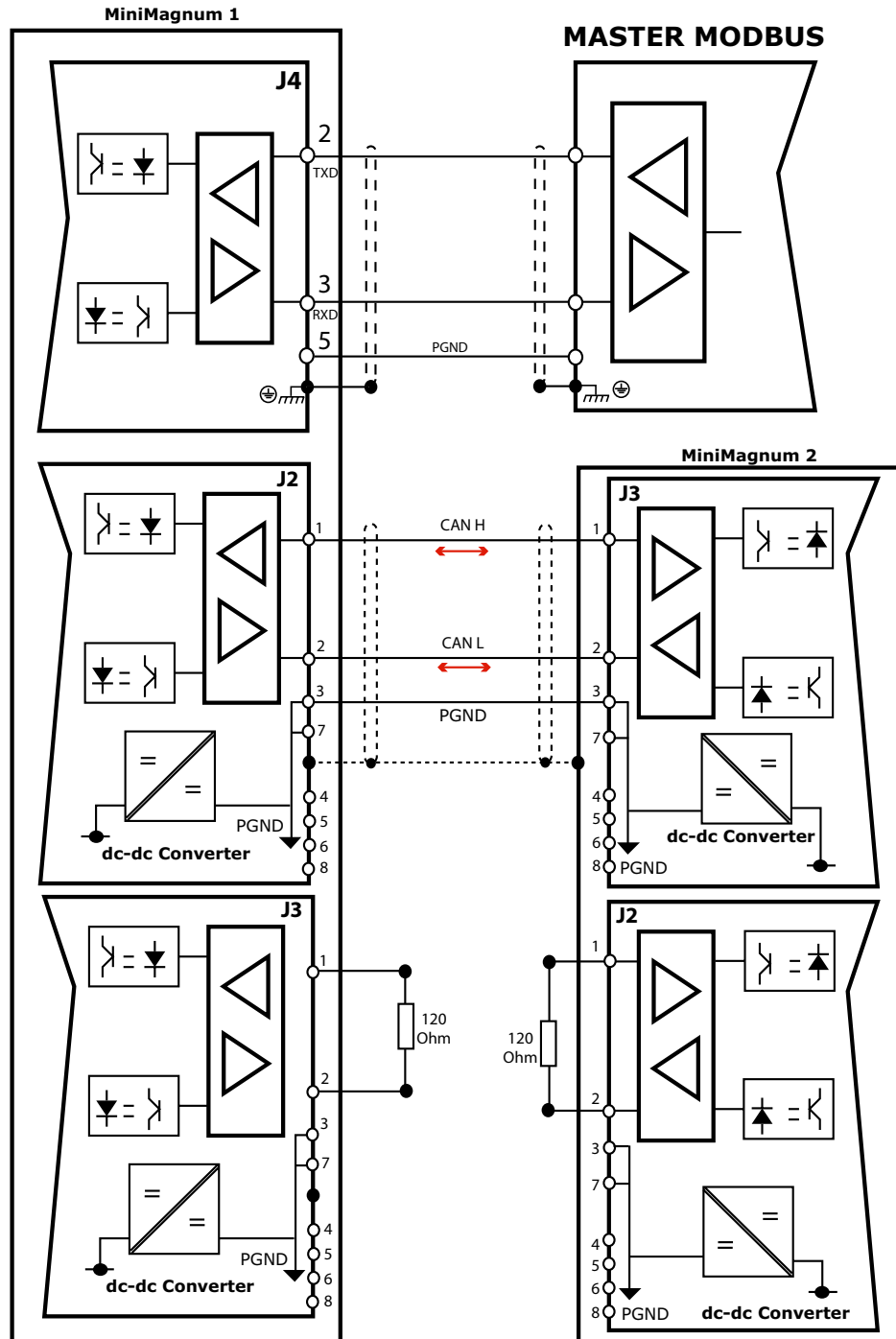

**Note:**

- Connect the first **MiniMagnum™** to the **Master** using the RS232 cable (**J4** connector); connect each additional drive with to the drive preceding it using the Can Bus cables and the **J2** and **J3** connectors; connect a **RESISTOR (120 Ohm, 1/4W)** between pins **1** and **2** of the **J2** (or **J3**) connector of the first **MiniMagnum™** and another resistor between pins **1** and **2** of the **J2** (or **J3**) connector of the last drive.

- Axor drives use **MODBUS communication protocol** specified in the **Modicon** instructions (see <http://www.modicon.com/techpubs/>).

For more information see enclosure "**Modbus Manual**" and "**CanOpen Reference Manual**" on the CD provided with the drive.

## 2.20 Canbus connection

### CANBUS connection

**OPTIONAL**

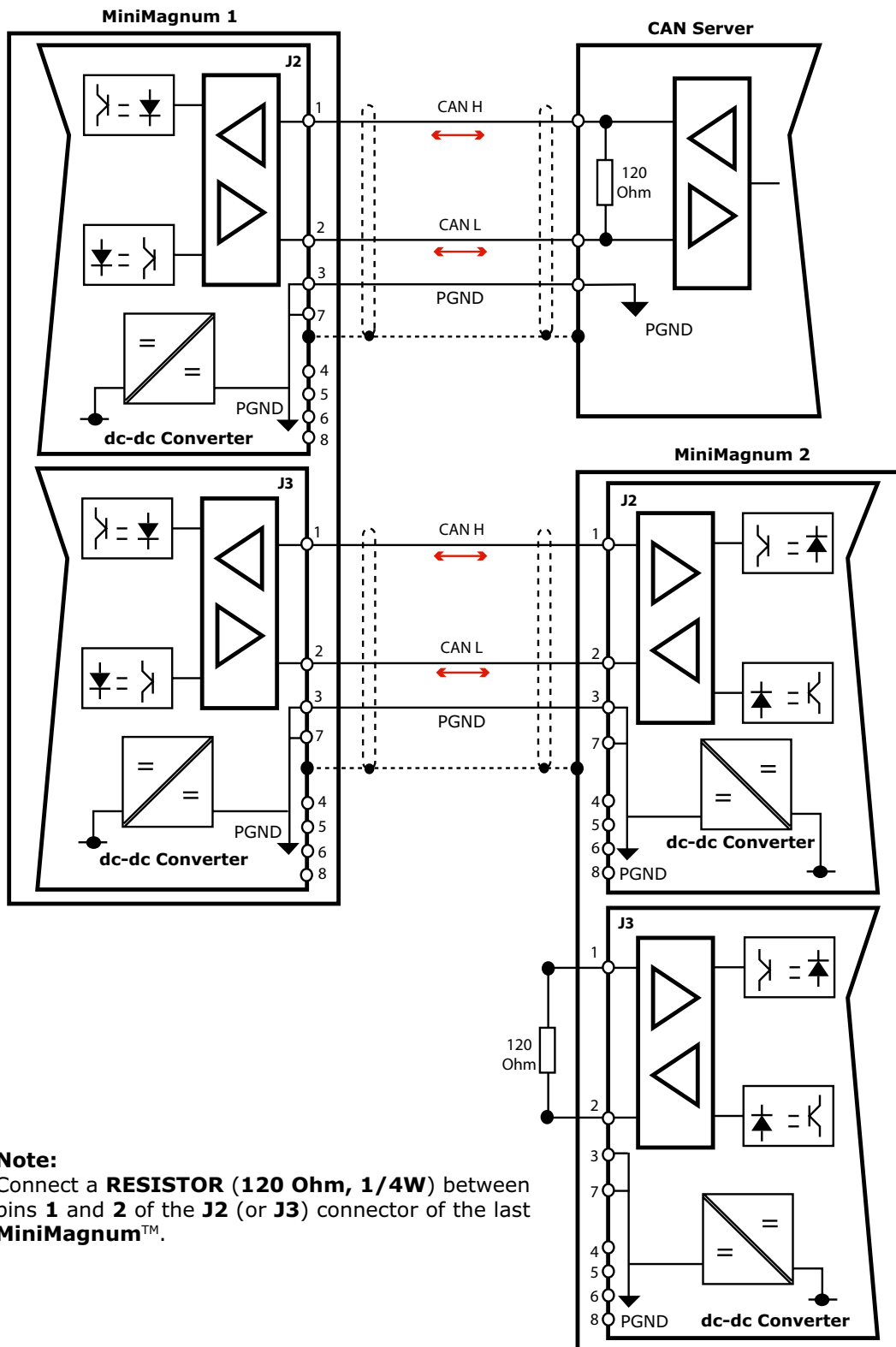

## 2.21 MiniMagnum™ power up

The power up of the **MiniMagnum™** must be done following this diagram, in order to save the drive and the electrical box:

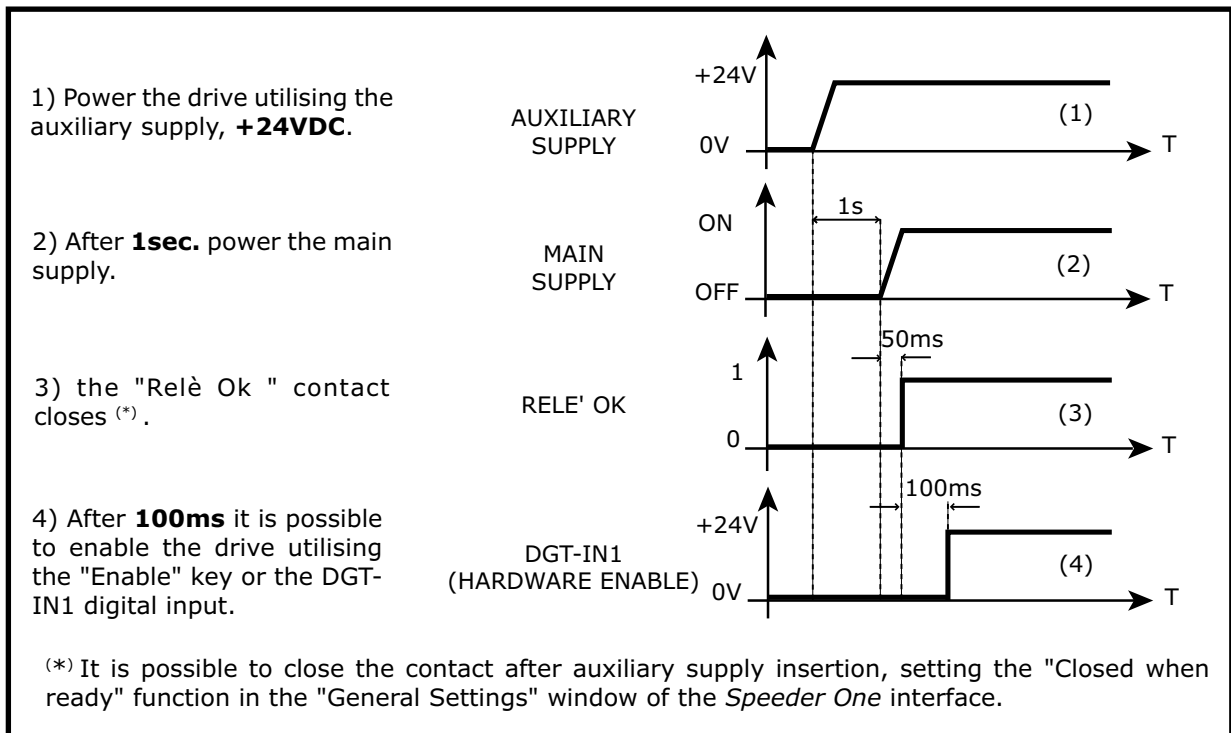

**Attention:** If the DGT-IN1 (ENABLE) digital input is enabled by the CN before powering the drive (A), after powering the drive utilising the auxiliary supply and the main supply, it is necessary to disable and enable the DGT-IN1 input (B), in order to enable the INTERNAL ENABLE. If the DGT-IN1 is not disabled, then re-enabled, the INTERNAL ENABLE remains disabled and the user cannot execute any movement.

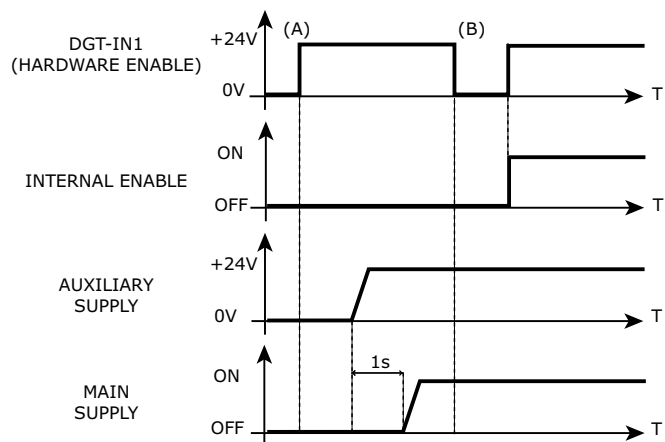

**Attention:** If the digital input DGT-IN1 (ENABLE) is enabled by the CN after powering the drive utilising the auxiliary supply, but before powering the drive utilising the main supply (C), it is necessary to disable and then re-enable DGT-IN1 input (D), in order to enable the INTERNAL ENABLE also. If the DGT-IN1 is not disabled then re-enabled, the INTERNAL ENABLE remains disabled and the user cannot execute any movement.

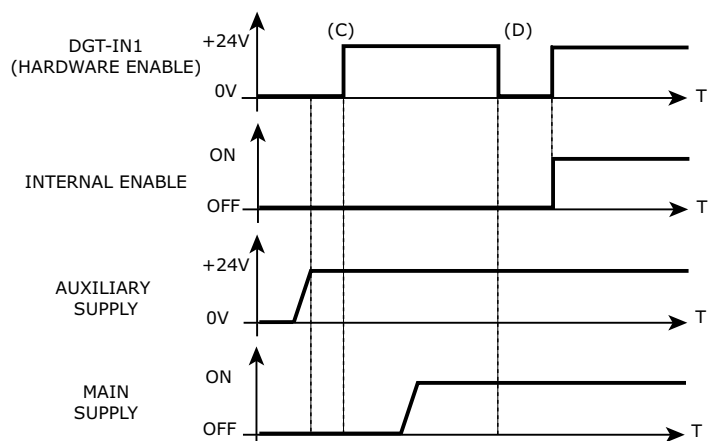

## 2.22 Motor Test



This procedure is a guide line for the first power up of the drive-motor system. **It must only be executed by technically qualified personnel. If you need more information contact Axor.**

- 1) Follow the basic procedure previously described. **ATTENTION: do not apply load to the motor.**
- 2) Install *Speeder One* interface from CD.
- 3) Power up the drive: apply the auxiliary supply and then the main supply (follow the procedure previously described).
- 4) Open the *Speeder One* interface clicking on "Axormb.exe" executable file on directory: "C:\Programm\Axor". The main window "**Axor Servo Drive**" and the "**Select Driver**" windows open simultaneously. On the **Select Driver** window insert the drive's address (all drives have **1 set** as default value), then click OK.

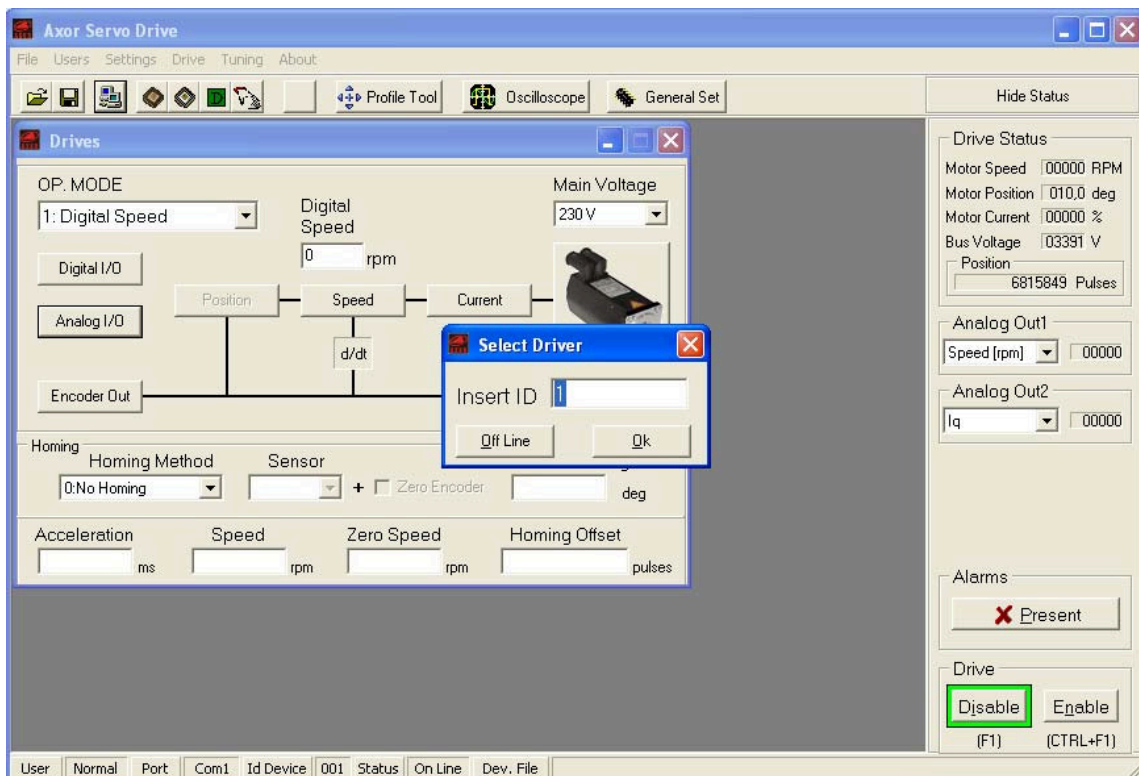

5) If the drive is "**Not configured**", it is necessary to open a pre-set configuration file, following this procedure:

- in the main window select the "**File**" menu and then "**Open**";
- in the directory: ...\Axor\Data\Devices\ select a file reference to the coupling drive-motor, then click on "**Open**";
- save load parameters by using "**Save Data To EEPROM**" icon.

If the drive is *configured for a specified motor*, it is sufficient to check these parameters:

- ✓ Main voltage (*Main Voltage* menu in the main window of the interface)
- ✓ Number of motor poles (*Motor* window)
- ✓ Feedback type (*Motor* window)
- ✓ Encoder impulse/rev or resolver n° of poles (*Motor* window)
- ✓ Irms current (*Current* window)
- ✓ Ipk current (*Current* window)
- ✓ Speed Limit (*Speed* window)

## 2.22 Motor Test

---

6) If alarms should appear, resolve them before going forward (see chapter 3).

7) Set the operative mode "**1: Digital Speed**", set a speed reference equal to 100rpm, enable the drive with the **Enable** button.

If shaft turns correctly, at the set speed, without alarms, it is possible to connect the load and cable the machine. It is possible to proceed with the connection of the load and with the wiring of the machine; on the contrary, if alarms should be compared or if the behavior should not be as set, we suggest to control the connections and the settings (eventually contact Axor).

8) Connecting the load to the motor, it should be necessary to connect gains of speed loop, following this procedure:

a- set the "**10: Square wave**" operating mode.

b- Set the "Speed\_RPM" parameter on the "Analog OUT1" menu.

c- Connect the probe of the oscilloscope on pins **AN.OUT1** (speed signal) and **AGND** (zero signal).

d- enable the drive

e- Adjust the KP and KI gains in a way that you obtain a stable step response in both directions. Increasing KP decreases the system's response time; however, the system gets closer to becoming unstable; therefore, during adjustment increase the KP to the oscillation limit and then reduce until secure oscillation stoppage.

Increasing KI the steady state diminishes, however increasing the overshoot, therefore after adjusting KP increase KI keeping the overshoot within authorized limits ( $\pm 10\%$ ).

The figure below illustrates some typical oscilloscope tracks:

A) Proportional and integral gains too low. Increase the numerical values of KP and KI.

B) and C) Good proportional and integral gains.

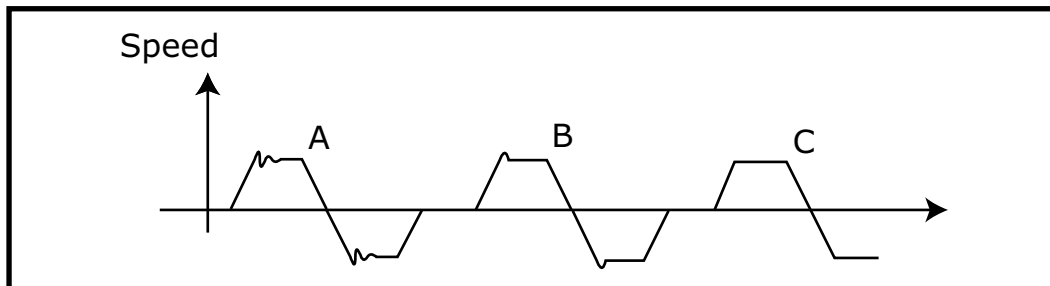

9) At this point it is possible to set other parameters in reference to the desired operative mode (see enclosures "**Operative Modes Manual**", "**Additional Features Manual**", "**Speeder One Interface**" available on the CD provided with the drive.



# Chapter 3

## Diagnostic

---

3.1 Display	42
3.2 Alarms	43

## 3.1 Display

A **display LED** visualises: the drive's status, the inserted values, the alarms.

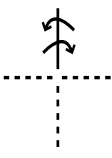
Symbol	Description
<b>F</b>	The digital input ENABLE is enabled, while the digital input set with the "Ref on" function is disabled.
<b>E</b>	The digital input ENABLE is disabled, while the digital input set with the "Ref on" function is enabled.
<b>[ ]</b>	The digital input ENABLE and the digital input set with the "Ref on" function are both enabled; the motor does not move.
 <p>(segment appears rotating in a clockwise or counter-clockwise direction)</p>	The rotor is turning in a clockwise or counter-clockwise direction.
<b>0i</b>	This appears when the negative limit switch (NSTOP) is interrupted.
<b>0 I</b>	This appears when the positive limit switch (PSTOP) is interrupted.
<b>- - -</b>	This appears when the converter is correctly powered on, the digital input ENABLE is disabled and there are no alarms.
<b>24 UP</b>	This appears when there is the +24VDC auxiliary supply, but not the main supply.
<b>ALxx</b>	There is alarm xx.

## 3.2 Alarms

The table below illustrates all the message errors:

ALARM		SOLUTION
AL1	<b>EEPROM alarm</b> Error while memorising parameter to the drive's EEPROM.	Disable the drive, try to memorise the parameter, then re-enable.
AL2	<b>Overcurrent alarm</b> Short circuit between U, V, W or towards earth.	Disconnect the power, verify the wiring, then power up again.
AL3	<b>Drive Temperature alarm</b> Heat sink temperature too high, >75°C.	Disable the drive, verify: <ul style="list-style-type: none"> <li>• the forced ventilation functioning,</li> <li>• the ambient temperature,</li> </ul> wait until the radiator has cooled off, reset the alarm then enable the drive.
AL4	<b>Hall alarm</b> This alarm comes on if one or more of the hall cell's wires are disconnected.	Disable the drive, verify the cell's wire connection, reset the alarm, then enable the drive.
AL5	<b>Encoder alarm</b> This alarm comes on if one or more of the encoder channels are interrupted.	Disable the drive, control the connections, reset the alarm, then enable the drive. If the alarm persists contact Axor.
AL6	<b>I<sup>2</sup>t Drive alarm</b> The internal I <sup>2</sup> t function has reached the maximum permitted. The cause could be one of the following: <ul style="list-style-type: none"> <li>• the working cycle could be too heavy;</li> <li>• a possible mechanical block;</li> <li>• motor phase inversion;</li> <li>• the electronic brake is not unblocked;</li> <li>• the amplifier's dynamic constants: "KP", "KI" and "KD", could create useless current oscillation.</li> </ul>	This does not cause the disabling of the drive's functioning.
AL7	<b>Motor Temperature alarm</b> Heat sink temperature too high. This causes the opening of the Ok Relè contact and the disabling of the functioning.	Disable the drive: <ul style="list-style-type: none"> <li>• control the heat sink temperature;</li> <li>• decrease the dynamic constant if the motor is vibrating. This situation causes current oscillation and consequently the overheating of the motor.</li> </ul> Wait until the motor has cooled off, reset the alarm, then enable the drive.
AL8	<b>Regenerative Resistance alarm</b> The value I <sup>2</sup> t energy recovery has reached the maximum allowed.	Disable the drive: <ul style="list-style-type: none"> <li>• check the AC power supply input;</li> <li>• check that the working cycles are not excessive;</li> <li>• verify if the motor, going at half speed, shows the same problem.</li> </ul> Reset the alarm, then enable the drive.
AL9	<b>Min/Max Voltage alarm</b> Minimum or maximum converter voltage.	Disable the drive, wait until the DC power supply voltage reaches the correct threshold, check the AC power supply input, then enable the drive.
AL10	<b>Pre-Alarm Recovery alarm</b> 80% of the I <sup>2</sup> t energy recovery value has been reached.	Check the AC power supply input and the working cycles. This is a visual alarm, it anticipates the intervention of the "Maximum recovery" alarm.

## 3.2 Alarms

<b>AL12</b>	<b>Resolver alarm</b> Missing resolver power supply/signal.	Disable the drive, control the resolver's contact, reset the alarm, then enable the drive.
<b>AL14</b>	<b>Following Error</b> The error between the position reference and the position feedback exceeds the "Max Position Error" parameter, because the "Max Position Error" parameter is too small, or the dynamic gains of the velocity-positioning loop are wrong.	Disable the drive, check the Max Position Error parameter, check the dynamic gains, reset the alarm, then enable the drive.
<b>AL15</b>	<b>Limit Switch</b> The two fixed limit switches have both been disabled or interrupted.	Disable the drive, check the limit limit switches and external connections, then enable the drive.
<b>AL17</b>	<b>Overcurrent regen resistance circuit</b> Possible short-circuit in the regen resistance circuit. This causes the opening of the Relè OK contact and the disabling of the functioning.	Power off the drive, control the short-circuit, then power on the drive.
<b>AL18</b>	<b>Mechanical Brake</b> Overcurrent at the internal brake command or wrong connections.	Disconnect the power: <ul style="list-style-type: none"> <li>• control the external connections;</li> <li>• control the current absorption of the motor brake;</li> <li>• verify the settings of the "Holding Brake" parameter on the "Motor" window;</li> </ul> then power up again.
<b>24 UP</b>	<b>In-rush Bus</b> <i>This is not an alarm.</i> Indication of the drive's in-rush phase or the lack of the main power supply.	
<b>AL20</b>	<b>Auxiliary Voltage</b> Presence of the main supply (L1, L2, L3), but the auxiliary +24Vdc voltage is missing.	Disable the drive, connect the Auxiliary Voltage, and then re-enable.
<b>AL23</b>	<b>Flash Alarm</b> Errors in reading/writing parameters on the Flash memory, or Flash memory is empty.	Disable the drive, save new values, then re-enable. If the problem persists contact Axor.
<b>AL24</b>	<b>Can Bus Alarm</b> Error during communication on CANBus.	Disable the drive, check the cabling and re-enable. If the problem persists contact Axor.
<b>AL26</b>	<b>Homing Error</b> Position error too high during the homing procedure. The motor stops, but it is not disabled.	Check the homing setup, then reset the alarm using the "Start Homing" function.

You can find more information in enclosure "**Alarm Manual**" available in the CD provided with the drive.

# Index

---

## **A**

Alarms 43  
analog common mode input (TPRC) 7, 10, 30  
analog differential or common mode inputs (+/-Vref) 7, 10, 30  
Analog outputs 7, 10, 29  
Auxiliary supply +24Vdc 24

## **B**

Braking Resistance 10

## **C**

Cables 19  
Canbus connection 36  
Conformity 47  
Connection to earth 20  
Connection to ground 20

## **D**

Digital inputs 7, 10, 28  
Digital output 7, 10, 29  
Display 7, 42  
Disposal 14

## **E**

EMI filter 8  
emulated encoder outputs 7, 31  
encoder connection 33  
Environmental conditions 18  
equipment 8  
Example of base connection 23  
Expansion cards 8  
External Protections 10

## **G**

General view 9

## **H**

Holding brake 8

## **I**

installation procedure 22

## **K**

KeyPad 7

# Index

---

## **M**

Maintenance 14  
Mechanical Dimension 11  
Mechanical specifications 11  
Motor holding brake 25  
Motor power 25  
Multidrop connection 35

## **N**

Nominal Data 10

## **O**

Operative Modes 6  
  CanBus 6  
  electrical axis 6  
  multidrop RS232 6  
  position control 6  
  pulse/direction mode 6  
  RS485 interface 6  
  speed control 6  
  Torque control 6  
Ordering code 12

## **P**

Positioning 17  
Power supply 24  
Product plate 12  
Pulse/Dir digital inputs 10, 32

## **R**

Regen resistance 26  
Rele' OK 27  
resolver connection 34

## **S**

Safety 8  
  black-out dynamic brake function 8  
  safety enable function 8  
Security standard 14, 15  
Shielding 21  
Speeder One 7  
Storage 14

## **T**

Transport 14

# Conformity

---

## European directives and norms

The servodrives are "*components*" that are intended to be incorporated into electrical plant and machines for industrial use.

When the servodrive is used into machines or plant, the electrical plant/machine must respect the following directives: **EC Machinery Directive (98/37/EC)**, **EC Directive on EMC (89/336/EC)**, **Low Voltage Directive (2006/95/EEC)**.

**The machine/plant manufacturer must examine whether with its machine/plant still further or other standards or EEC guidelines are to be used.**

## EC Conformity

The **EC** mark that is applied to the drives references to the **Low Voltage Directive (2006/95/EC)** and **EC Directive on EMC (89/336/EC)**.

The standard EN 61800-5-1 is applied to ensure conformance with the Low Voltage Directive.

The standard EN 61800-3 is applied to ensure conformance with the EMC Directive.

In reference to noise immunity and noise emission the converters fulfil the requirement to the category *second environment* (industrial environment).

If the installation of the drive is carried out differently than described in this manual, the user must carry out new measures to satisfy the requisites of law.

**UWE**  
  
**POPHOF**  
ANTRIEBSTECHNIK  
& AUTOMATION

Postfach 1967  
D-77909 LAHR  
Schützenstr. 14a  
D-77933 LAHR  
Tel.: 07821 / 98 39 13  
Fax: 07821 / 98 39 14  
Funk: 0171 80 38 472  
Mail: info@pophof.de  
www.pophof.de



**AXOR INDUSTRIES®**

viale Stazione, 5  
36054 Montebello Vic.  
Vicenza - Italy

phone (+39) 0444 440441  
fax (+39) 0444 440418  
info@axorindustries.com

[www.axorindustries.com](http://www.axorindustries.com)

