



# elap MEM-Bus

## Single & Multi-turn Absolute Encoders With Fieldbus Interface

- Singleturn and Multiturn Absolute Encoders
- CANopen or Profibus DP Fieldbus
- High resolution
- Several mechanical versions available
- Strong and reliable

### MECHANICAL & ENVIRONMENTAL SPECIFICATIONS

TYPE	MEM520-Bus	MEM540-Bus	MEM620-Bus	MEM410-Bus	MEM430-Bus
	Ø.58 mm round flanged – servo coupling SIZE23	Ø.58 mm round flanged Ø 36 mm centering mask	mm63.5x63.5 square flanged SIZE25	Hollow shaft for motor coupling	Hollow shaft Fixing with elastic support
• Weight	500 g ca.				
• Materials: case	aluminium				
• Shaft	stainless steel				
• Shaft diameter/ Joint hole	6, 8, 10 mm			Hole Ø 8, 10, 12, 14, 15 mm	
• Revolutions/minute	6000				
• Starting torque	≤0,8Ncm				
• Inertia	≤25g cm <sup>2</sup>				
• Max load	80 N axial / 100 N radial				
• Shock resistance (11 ms)	50 G				
• Vibration resistance (10÷2000 Hz)	100 m/sec <sup>2</sup>				
• Protection degree	IP65				
• Operating temperature	-30 ÷ +70°C				
• Stocking temperature	-30 ÷ +85°C				

### CARATTERISTICHE ELETTRICHE E FUNZIONALI

• Operating principle	magnetic
• Resolution/revolution	8192 step/rev. – 13 bit
• Revolutions no. (multiturn)	65536/16 bit
• Initializing time	< 1 s
• Data memory	>21 years power off*
• Fieldbus Interface	CANopen, Profibus DP
• Supply	5 ÷ 28 Vdc Protection against polarity reversal
• Consumption	2 W
• Accuracy	± ½ LSB
• Connection outlet	3 cable glands or 2 cable glands
• Interference immunity	EN 61000-6-2
• Emitted interference	EN 61000-6-4

\* Stopped shaft

### SETTABLE PARAMETERS

- Steps/revolution
- Revolutions number
- Preset
- Rotation direction

### DIAGNOSTIC FUNCTIONS

- Position or parameter error
- Battery alarm

### STATE INDICATORS

- 3 signalling LEDs for
- Supply
- Line
- Error (CANopen)



POPHOF Antriebstechnik  
Schützenstr. 14a, D-77933 Lahr

Tel. 07821-983 913  
Fax 07821-983 914

info@pophof.de  
www.pophof.de

ELAP INDUSTRIAL AUTOMATION VIA VITTORIO VENETO, 4 – I-20094 CORSICO (MI)  
TEL. ++39.02.4519561 FAX ++39.02.45103406 E-MAIL: INFO@ELAP.IT URL: WWW.ELAP.IT

## DIMENSIONS

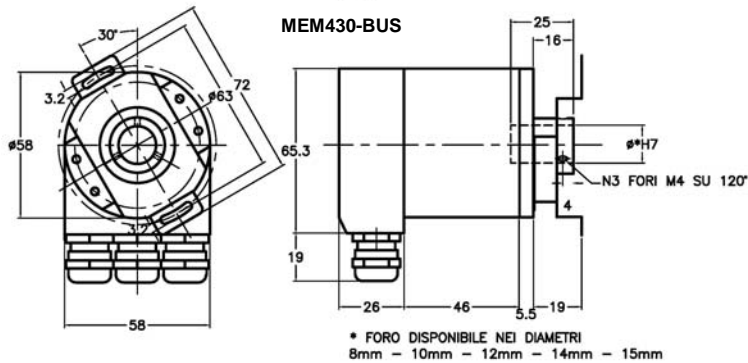
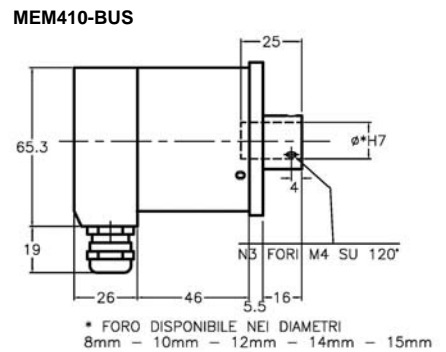
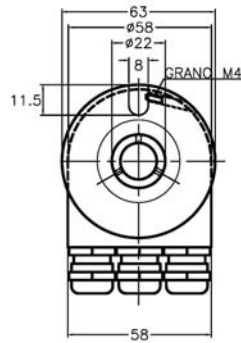
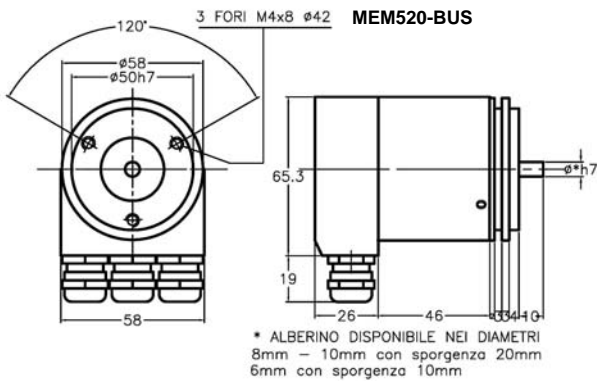
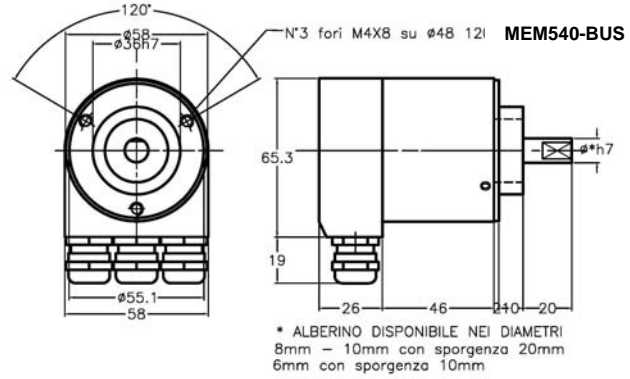
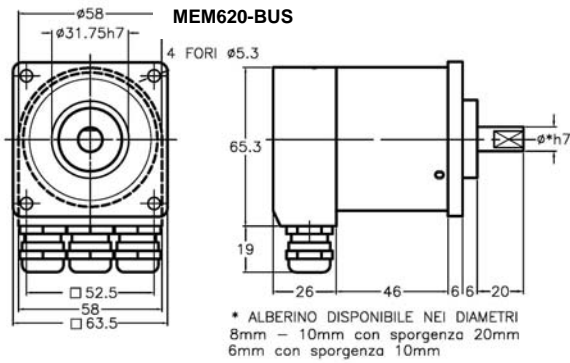

## ORDERING INFORMATION

<b>MEM520</b>	<b>CAN</b>	<b>M</b>	<b>10</b>	<b>3P</b>
---------------	------------	----------	-----------	-----------

### CONNECTIONS TYPE

3P = 3 cable glands  
2P = 2 cable glands

### SHAFT DIAMETER/JOINT HOLE

6 - 8 - 10 - 12 - 14 - 15 mm

### REVOLUTIONS NO.

M = Multiturn  
S = Singleturn

### FIELDBUS INTERFACE

CAN= CANopen  
PDP = Profibus DP

### TYPE

**MEM520-Bus** = 58 mm diameter round flange  
**MEM540-Bus** = 58 mm diameter round flange  
**MEM620-Bus** = 63.5x63.5 mm square flange  
**MEM410-Bus** = Hollow shaft for motor coupling  
**MEM430-Bus** = Hollow shaft with elastic support



**POPHOF Antriebstechnik**  
Schützenstr. 14a, D-77933 Lahr

**Tel. 07821-983 913**  
**Fax 07821-983 914**

**info@pophof.de**  
**www.pophof.de**

ELAP INDUSTRIAL AUTOMATION VIA VITTORIO VENETO, 4 - I-20094 CORSICO (MI) TEL. ++39.02.4519561 FAX ++39.02.45103406 E-MAIL: INFO@ELAP.IT URL: WWW.ELAP.IT