

SERVICE MANUAL

AXOR INDUSTRIES®

ENGLISH



CE

FAST-BACK®

Powered Brushless Motor



Twenty years of great motordrives

Release	Note
ver.1 rev.03/06	First edition.
ver.1 rev.06/06	Corrections.
ver.1 rev.07/06	New cover. New paging.
ver.1 rev.09/06	Corrections. New paragraph. Insert mechanical curves. Insert Index.
ver.1 rev.01/07	Insert Fast Back 100 technical data.
ver.1 rev.02/07	Insert chapter "5:Application" about: Reset Fault Function, Emergency Function, Positioner and Homing procedures, Motor Brake Management, Stop Functions. Corrections.
ver.1 rev.03/07	Corrections.
ver.1 rev.04/07	Insert note about power supply transformer.
ver.2 rev.08/07	Manual re-organisation: first base version.
ver.2 rev.11/08	Mechanical dimensions were update. Corrections.
ver.2 rev.01/10	Absolute encoder feedback inserted. Torque derating with temperature. Notes about canbus cable inserted. Corrections.

All rights reserved. Reproduction in whole or in part is prohibited without prior written consent of the copyright owner. All specifications are subject to change without prior written consent of the copyright owner. All specifications are subject to change without prior notification.

Print in Italy 01/2010



**THIS MANUAL CONTAINS A DESCRIPTION OF Fast Back™
AND A GUIDELINES FOR THE DRIVE'S INSTALLATION;
FOR MORE DETAILS SEE ENCLOSURES ON THE CD PROVIDED WITH THE DRIVE.**

**USING THE DRIVE INCORRECTLY CAN INJURE PEOPLE OR DAMAGE THINGS.
FULLY RESPECT THE TECHNICAL DATA AND INDICATIONS
ON CONNECTION CONDITIONS.**

Index

1) Description

1.1 Product description	6
1.2 Technical data - General	8
1.3 General view - Fast Back	9
1.4 Technical data - Fast Back 75	10
1.5 Technical data - Fast Back 100	11
1.6 Mechanical dimensions - Fast Back	12
1.7 Mechanical Curves - Fast Back 75	13
1.8 Mechanical Curves - Fast Back 100	14
1.9 Ordering Code	15

2) Installation

2.1 Important notes	18
2.2 Example of connection	20
2.3 Power Supply connection	21
2.4 IN/OUT Digital connection	24
2.5 Can Bus Interface	26
2.6 RS485 Interface	28
2.7 RS232 Interface	29
2.8 Multidrop	30
2.9 Led	32

3) Protections and Alarms

3.1 Protections	34
3.2 Alarms	35

Index	37
--------------	-----------

Conformity	39
-------------------	-----------

Enclosures to the manual

On the CD provided with the drive there are the following enclosures (in pdf):

- Additional Features Manual (it contains informations about: Emergency Function, Reset Fault Function, Holding Brake Management, Stop Functions)
- Speeder One Interface for Fast Back™
- Positioner Manual
- ModBus Manual
- CanOpen Reference Manual

Chapter 1

Description

1.1 Product description	6
1.2 Technical data - General	8
1.3 General view - Fast Back	9
1.4 Technical data - Fast Back 75	10
1.5 Technical data - Fast Back 100	11
1.6 Mechanical dimensions - Fast Back	12
1.7 Mechanical Curves - Fast Back 75	13
1.8 Mechanical Curves - Fast Back 100	14
1.9 Ordering Code	15

1.1 Product description

The **Fast Back™** is an all in one fully digital DRIVE plus BRUSHLESS MOTOR.

There are two available sizes:

- ✓ **Fast Back 75**: having a continuous stall torque from 1.1Nm to 3.8Nm;
- ✓ **Fast Back 100**: having a continuous stall torque from 3.2Nm to 7.5Nm.

OPERATIVE MODES		
CANBUS	It can be configured and controlled using CanBus . It supports the following Can Open protocols: <ul style="list-style-type: none"> • part of the DS301-V4.02 • part of the DSP402-V2.0 	standard
MULTIDROP RS232	It can work in Multidrop , where the first drive, connected via RS232 to the Master PC, is piloted with <i>ModBus communication</i> , while the other drives are piloted with the duplication of commands using the <i>CanBus interface</i> .	standard
SPEED CONTROL	It is speed piloting utilising a digital reference.	standard
TORQUE CONTROL	It is torque piloting utilising a digital reference.	standard
POSITION CONTROL	The positioner can be managed via hardware (by using the digital inputs) or via RS232 (by using the Axor's <i>Speeder One</i> interface or another ModBus Master). It supports <i>32 programmable position profiles</i> ; a <i>single task</i> or a <i>sequence of tasks</i> are permitted. The Homing Procedure is implemented. It uses the signal coming from the <i>homing sensor</i> and eventually the <i>zero signal</i> of the encoder.	standard
RS485 INTERFACE	It is possible to communicate with two or more drives by using the RS485 interface .	<i>optional</i>
Notes:		
<ul style="list-style-type: none"> • The current controller is vectorial with sampling time of 50µs. The velocity and position loop both work with sampling time of 200µs. • The current commutation is sinusoidal. 		
FEEDBACK		
ENCODER	incremental encoder signals (2048RPM) plus hall signals	standard
	absolute encoder with endat interface	<i>optional</i>
DIGITAL and ANALOG INPUTS/OUTPUTS		
2 DIGITAL INPUTS (1 programmable)	They are programmable for: the limit switch, the holding brake, the homing and positioning procedures, the emergency stop, the reset alarm, etc.	standard
1 programmable DIGITAL OUTPUT	It can be used to send messages from pre-programmed functions of the drive.	standard

1.1 Product description

GENERAL FEATURES		
SPEEDER ONE SOFTWARE INTERFACE	It allows you to set and manage all drive's parameters by using a PC connected to the drive. The communication between the drive and PC is done by a RS232 cable using the ModBUS protocol. The software works on the following operating systems: Windows 98, Windows 2000, Windows XP.	standard
LED	There is a led which allows you to control the drive's functioning.	standard
EMI FILTER	The drive is equipped with an integrated EMI anti-disturbance filter at the 3-phase power supply input.	standard
REGEN CIRCUIT		standard
SECURITY		
SAFETY	The converter is protected from short circuitry, the Max/Min Voltage, the drive I^2t , the Motor I^2t , etc.	standard
SAFETY ENABLE FUNCTION	It is a personnel safety function which avoids the accidental startup of the motor in the absence of 24Vdc on indicated pin.	<i>optional AVAILABLE SOON</i>

1.2 Technical data - General

Power Supply		
Power supply	Vac	220Vac \pm 10% 3-phase, 50/60Hz 220Vac \pm 10% single phase, 50/60Hz (IT DOES NOT ALLOW THE RATED PERFORMANCE, contact Axor's technical department for details)
Logic supply (for back-up only)	Vdc	24Vdc (\pm 10%) - 200mA
Logic supply (back-up + brake)	Vdc	24Vdc (\pm 5%) - 500mA for Fast Back 75 24Vdc (\pm 5%) - 800mA for il Fast Back 100

Environmental Conditions	
Operating temperature at rated data	0÷45°C (no derating) 45÷55°C (Mo and Mpk derating: 2.5%/°C)
Max operating temperature	55°C max
Storage temperature	-20...+55°C
Humidity	From 10% to 80% max. without condensation
Altitude	Up to 1000m without restrictions. From 1000 to 2500m power derating 1.5%/100m
Pollution Level	Level 2 (normS EN60204)
Enclosure protection	IP54 (optional IP65 and IP65S)
Notes:	
<ul style="list-style-type: none"> The electrical box must have suitably filtered air vents. An area of at least 15cm around the Fast Back™ is required. Periodically check drive case and fans for excess dust or dirt, that could interfere with the correct dissipation of the drive. 	

Inputs/Outputs	
Digital output	+24Vdc - 50mA
Digital inputs	+24Vdc - 7mA

Cables sections	
Power supply cables	1.5mm ² /16AWG
Signals cables	0.34mm ² /22AWG

1.3 General view - Fast Back

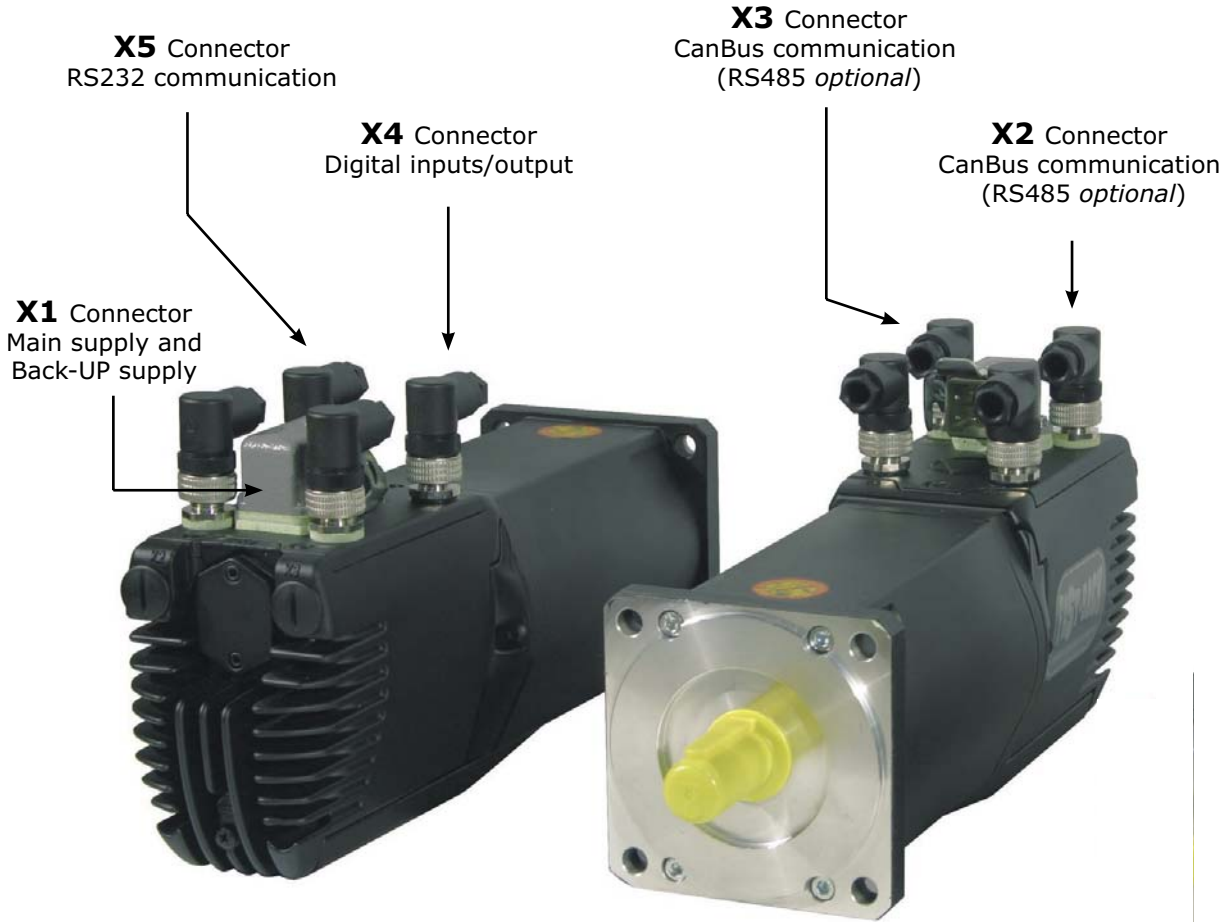

1.4 Technical data - Fast Back 75

FAST BACK - serie 75					
Performance Data					
SIZE		XS	S	M	L
Stall Torque, Mo	Nm	1.1	1.6	2.7	3.8
Peak Stall Torque, Mpk	Nm	3.3	4.8	8.1	10
Rated speed, Nn	Rpm	3000	3000	3000	3000
Rated torque at Nn, Mn	Nm	0.95	1.45	2.35	3.3
Mechanical Data					
Weight	Kg	2.85	3.3	4.2	5.0
Weight with brake	Kg	3.45	3.9	4.8	5.6
Rotor inertia	(Kgm ²)10 ⁻⁴	0.4	0.6	1	1.4
Brake inertia	(Kgm ²)10 ⁻⁴	0.122			
External fuses					
Size		XS/S		M/L	
AC Supply L1-L2-L3 (F₂)		6AT		10AT	
Auxiliary Supply +24VDC		6AT			

1.5 Technical data - Fast Back 100

FAST BACK - serie 100				
Performance Data				
SIZE		S	M	L
Stall Torque, Mo	Nm	3.2	5.2	7.5
Peak Stall Torque, Mpk	Nm	10.3	10.5	15
Rated speed, Nn	Rpm	3000	3000	2200
Rated torque at Nn, Mn	Nm	2.8	4.5	6.4
Mechanical Data				
Weight	Kg	5.8	7	8.2
Weight with brake	Kg	6.5	7.7	8.9
Rotor inertia	(Kgm ²)10 ⁻⁴	1.8	2.8	3.8
Brake inertia	(Kgm ²)10 ⁻⁴	0.37		
External fuses				
Size	S/M/L			
AC Supply L1-L2-L3 (F₂)	10AT			
Auxiliary Supply +24VDC	6AT			

1.6 Mechanical dimensions - Fast Back

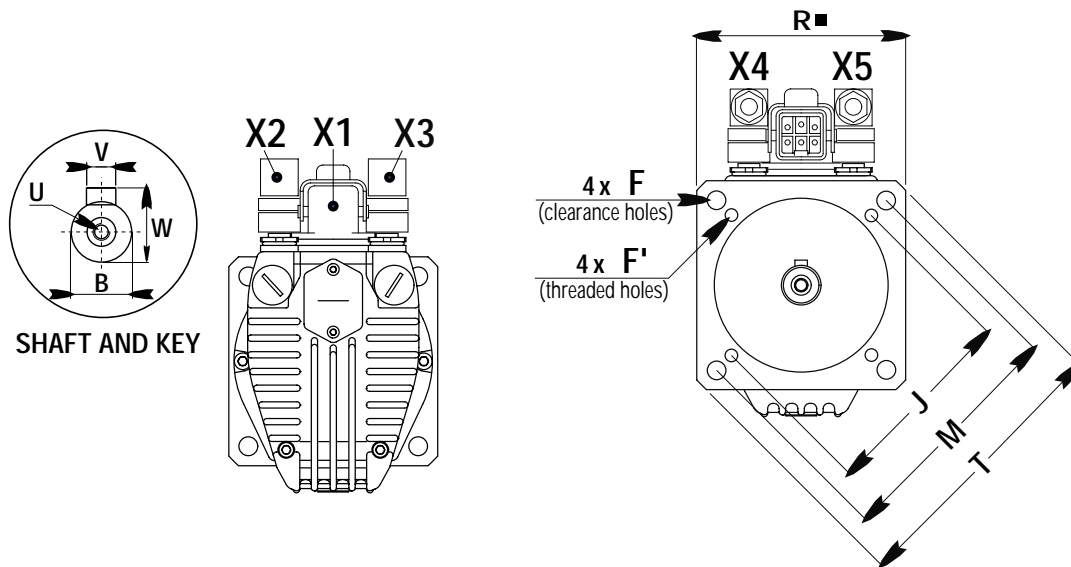
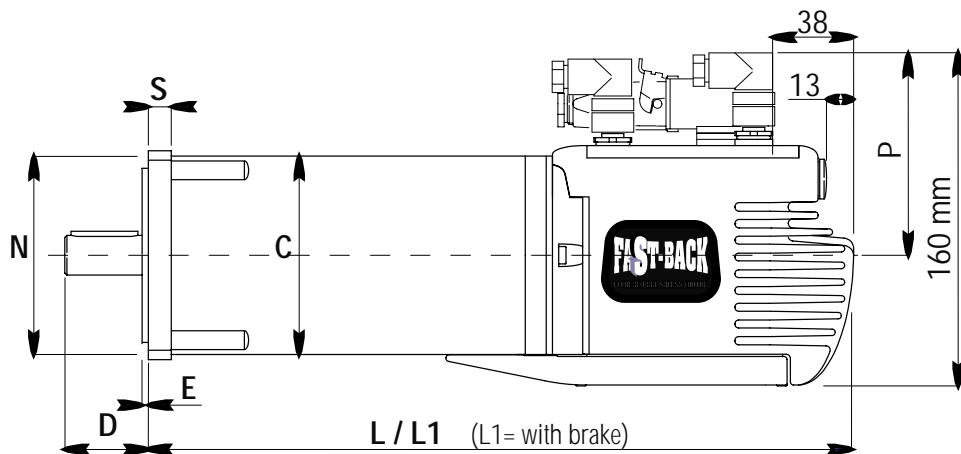

Mechanical dimensions - Fast Back 75 and 100																			
	L	L1	$B_{\frac{1}{2}}$	D	V_{90}	W	U	$N_{\frac{1}{2}}$	M	F	J	F'	E	S	R_{\square}	T	C	P	
Serie - Mo (Nm)	mm	mm	mm	mm	mm	mm	mm	mm	mm	mm	mm	mm	mm	mm	mm	mm	mm	mm	
FBK 75 XS - 1.1	230	285	11	23	4x18	12.5	M4x10	60	90	5.5	75	M5x8	2.5	10	75	100	75	107	
FBK 75 S - 1.6	245	300																	
FBK 75 M - 2.7	275	330																	
FBK 75 L - 3.8	305	360	14	30	5x25	16													
FBK 100 S - 3.2	301	359	19	-	6x32	21.5	M6x16	95	115	9	-	-	3	12	100	135	95	97	
FBK 100 M - 5.2	336	394																	
FBK 100 L - 7.5	371	429																	

1.7 Mechanical Curves - Fast Back 75

The **Fast Back™** series **75** has the following **mechanical curves**:

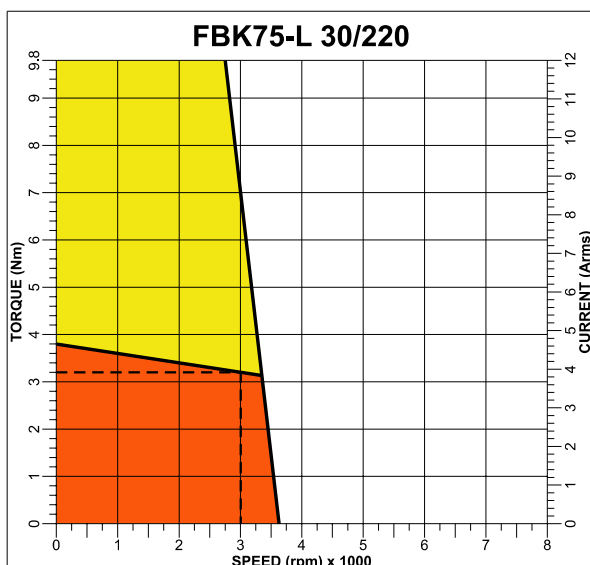
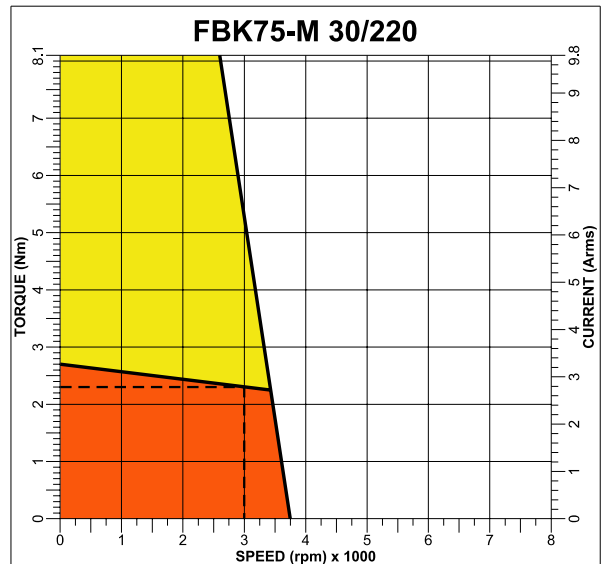
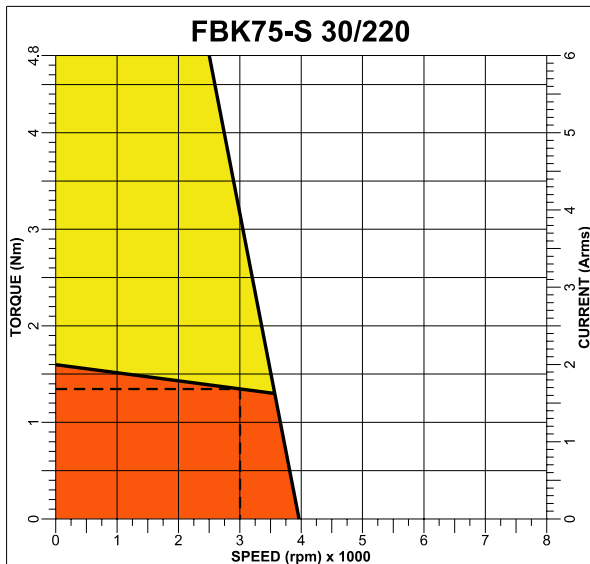
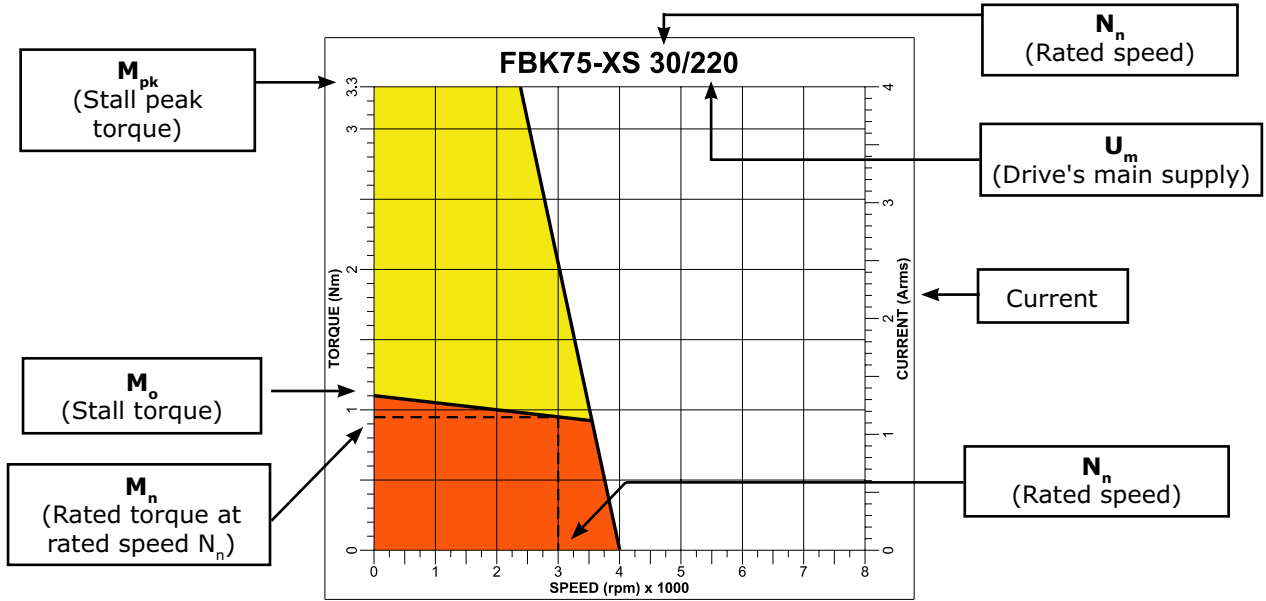

1.8 Mechanical Curves - Fast Back 100

The **Fast Back™** serie **100** has the following **mechanical curves**:

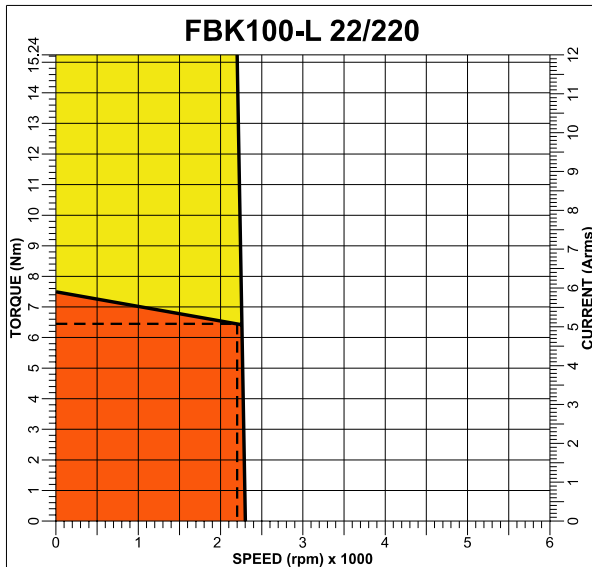
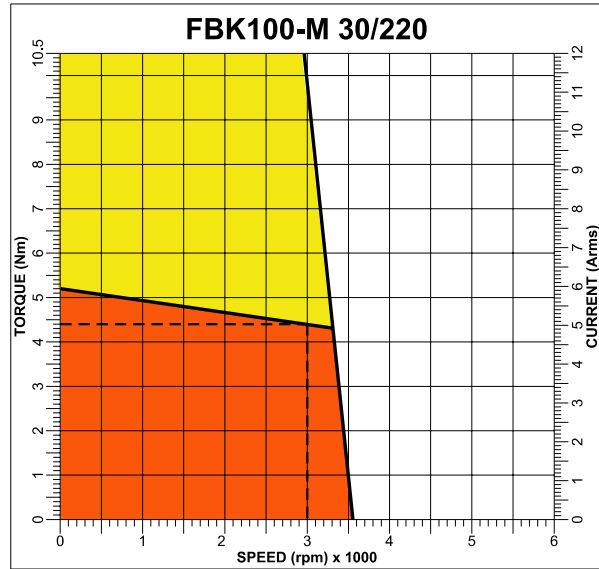
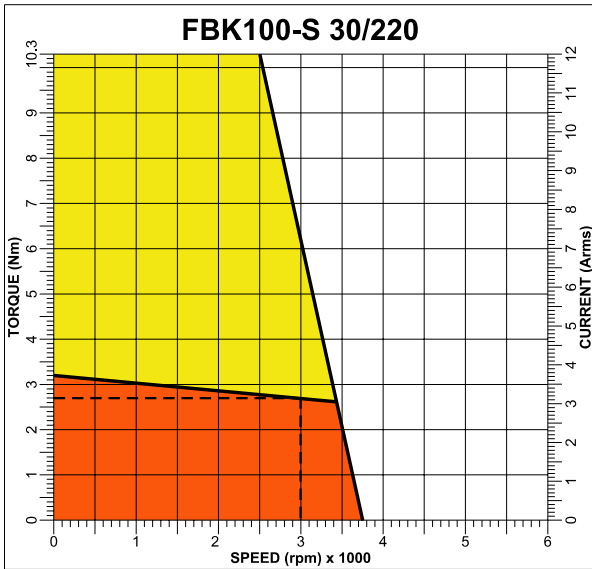

1.9 Ordering Code

On the side of each **FastBack™** there is a **product plate** like the following:

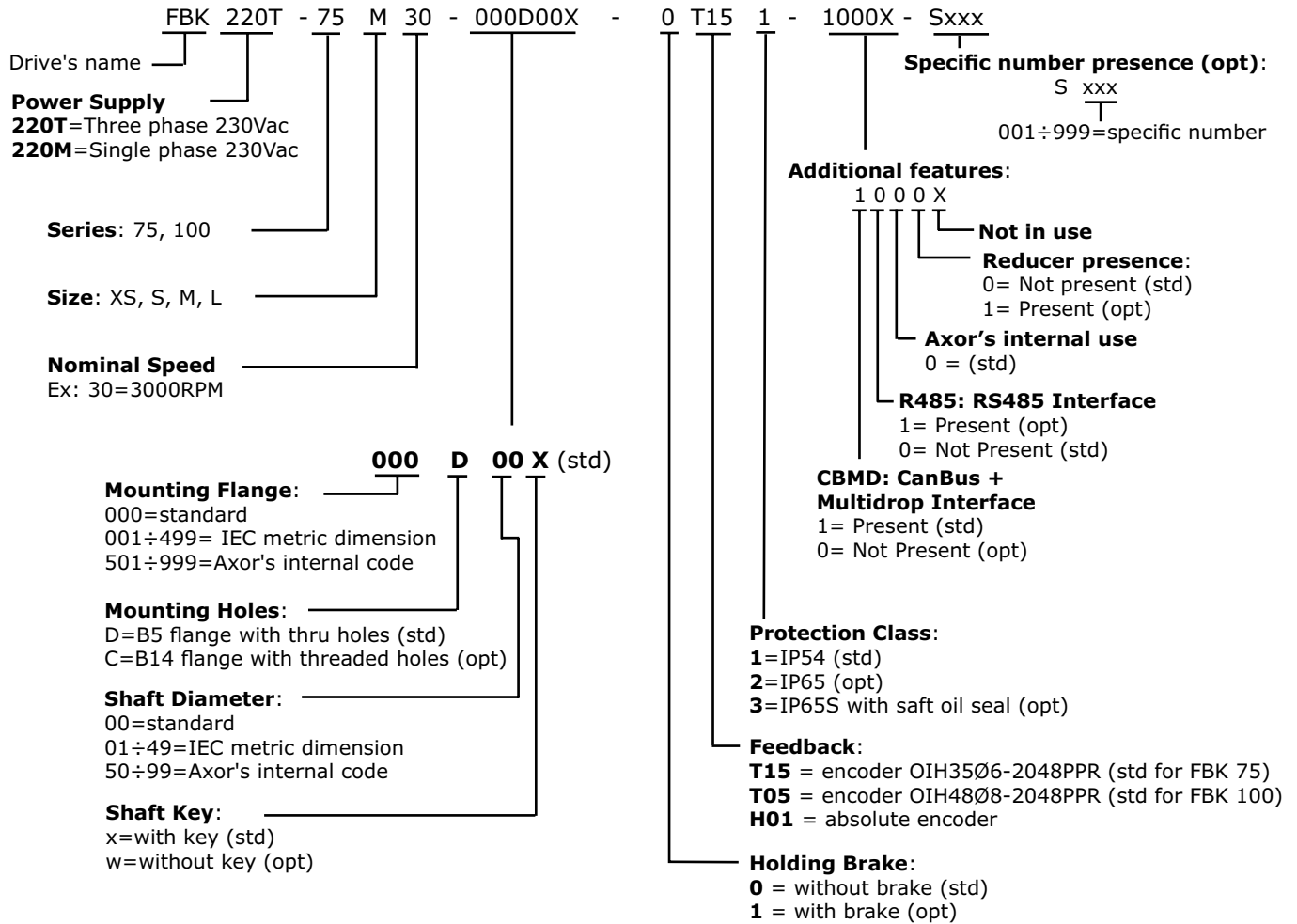

Special Flanges & Shafts (optional)	B _{j6}	D	V _{h9}	W	U	N _{j6}	M	F	J	F'	E	S	R □	T
100D14X (FBK 75 all sizes)	14	30	5X25	16	M4x10	80	100	6.6	-	-	3	10	90	115
130D14X (FBK 75 all sizes)	14	30	5X25	16	M4x10	110	130	9	-	-	3.5	10	115	150
100C19X (FBK 100 all sizes)	19	40	6X32	21.5	M6x16	80	-	-	100	M6X10	3	12	95	120
115D24X (FBK 100 all sizes)	24	50	8X40	27	M8x19	95	115	9	-	-	3	12	100	135
100D11X (FBK 75 XS, S M)	11	23	4X18	12.5	M4X10	80	100	6.6	-	-	3	10	90	115
130D19X (FBK 100 all sizes)	19	40	6X32	21.5	M6X16	110	130	9	-	-	3.5	12	115	150
130D24X (FBK 100 all sizes)	24	50	8X40	27	M8X19	110	130	9	-	-	3.5	12	115	150

Chapter 2

Installation

2.1 Important notes	18
2.2 Example of connection	20
2.3 Power Supply connection	21
2.4 IN/OUT Digital connection	24
2.5 Can Bus Interface	26
2.6 RS485 Interface	28
2.7 RS232 Interface	29
2.8 Multidrop	30
2.9 Led	32

2.1 Important notes

Transport

During the transport of the drive respect the following indications:

- the transport must be made by qualified personnel;
- avoid shocks;
- the temperature range must be between -20°C and +55°C;
- the max. humidity must be 95% (without condensation);
- the converters contains elements which are sensitive to electrostatic discharges. These elements can be damaged by careless manipulation.

Discharge static electricity from your body before touching the converter.

Avoid contact with material that insulates well (synthetic fibres, films of plastic material and so forth).

- we suggest to check the drive condition at its arrival to survey eventual damages.

Storage

The unused drives must be storage in an environment having the following characteristics:

- temperature from -20°C to +55°C;
- max. relative humidity 95% (without condensation);

The max. time with the drive powered off (without supply connections) should be **1 year**.

After this time, before enable the drive, it is necessary activate the capacitors following this procedure: remove all electrical connections, then supply the input terminals of the supply with the main voltage (three phase or single phase) for 30 minutes. So, in this case power the **Fast Back!**TM by using a single phase (or three phase) supply equal to 110÷130VAC.

In order to avoid this procedure, we suggest to power on the drive with its rated voltage for 30 minutes, before the max. time is reached.

Maintenance

The drives does not need maintenance. Otherwise, if the casing is dirty clean it.

Disposal

The disposal should be carried out by a certified company.

2.1 Important notes

Security standard

- **This manual is exclusively addressed to technical personnel with the following requirements:**

- Technician with knowledge on movimentation of elements sensitive to electrostatic discharges (for the transport).
- Technician with an appropriate technical training and with vast knowledge on electrotechnics/drive technical field (for the installation and for operate the servodrive). Using the drive incorrectly can injure people or manage things. Fully respect the technical data and indications on connection conditions.



- As well as the points described in this manual, current regulations regarding safety and accident prevention must be followed in order to prevent accidents and residual risks.

- The user must analyse possible machine risks and take the necessary measures to avoid injuries to people and damage to things because of unpredictable movements.

- The converters contains elements which are sensitive to electrostatic discharges. These elements can be damaged by careless manipulation.

Discharge static electricity from your body before touching the converter.

Avoid contact with material that insulates well (synthetic fibres, films of plastic material and so forth).

- During operation, the converter surface can become hot. Protect the user from accidental contact and keep the indicated distances from every object.

- Never loosen electrical connections while the servoamplifiers are being powered. The appropriate terminals of the drive must always be connected to earth as instructed in this manual. After having disconnected the converters from the supply current, always wait at least 5 minutes before touching the powered components (e.g. contacts) or loosening connections.

- The command and power connections can still hold current even when the motor has stopped.

- The **Fast Back™** is equipped with electronic protections that deactivate it in case of irregularities.

- Protect the converter from excessive mechanical vibrations in the electric box.

- Always section all of the products' power phases, utilising a power relay or a thermal magnet. In the case of three phase interrupt L1, L2 and L3.

- Make sure that the **Fast Back™** is earth-connected in accordance with the current norms. See the connection diagram on the next page.

2.2 Example of connection

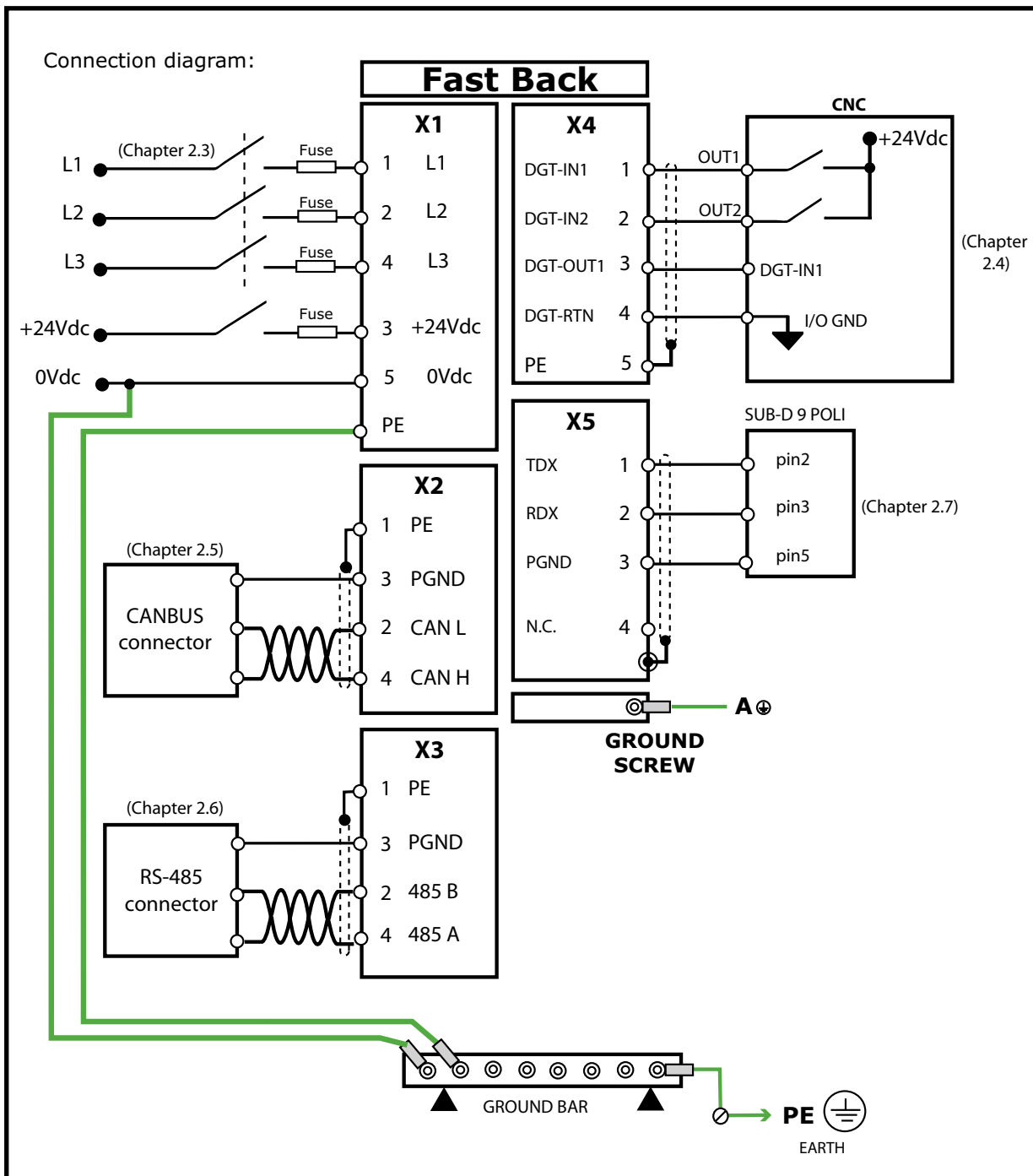

In the following paragraphs there is a detailed description about Fast Back™ interfaces and many connection examples.

2.3 Power Supply connection

The **X1 connector** contains:

- the **alternate supply** coming from the mains;
- the **+24VDC external power supply**.

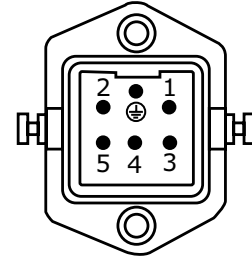

Male connector, X1
(Front view)

X1 Connector - Power supply and Back-UP supply	
PIN	DESCRIPTION
1	Power supply, L1
2	Power supply , L2
3	Back-up supply, +24V
4	Power supply, L3
5	Back-up ground reference, 0V
6, PE	Connection to Earth

Power supply connection diagram:

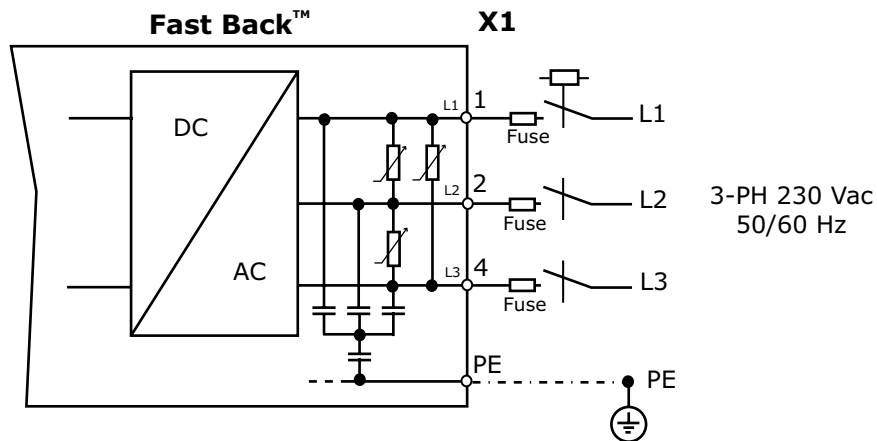

2.3 Power Supply connection

The **Fast Back™** has the following power supply: **three phase or single phase 220Vac ±10%**. The single phase power supply DOES NOT ALLOW THE RATED PERFORMANCE, contact Axor's technical department for details. The product is opto-isolated and this guarantees the galvanic isolation between the mains and control signals.

Examples of connection (**three phase** power supply):

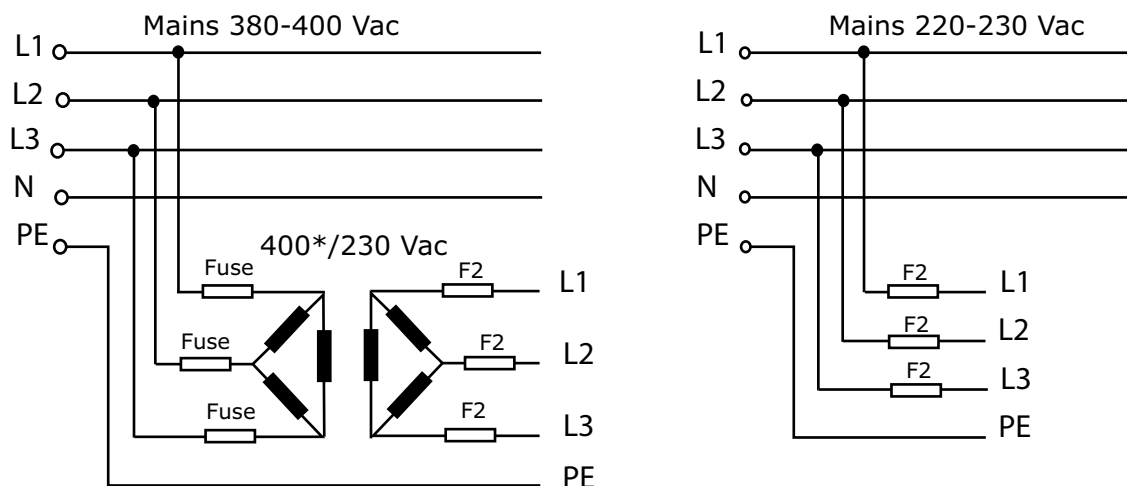

* It depends by the available main supply.

Examples of connection (**single phase** power supply):

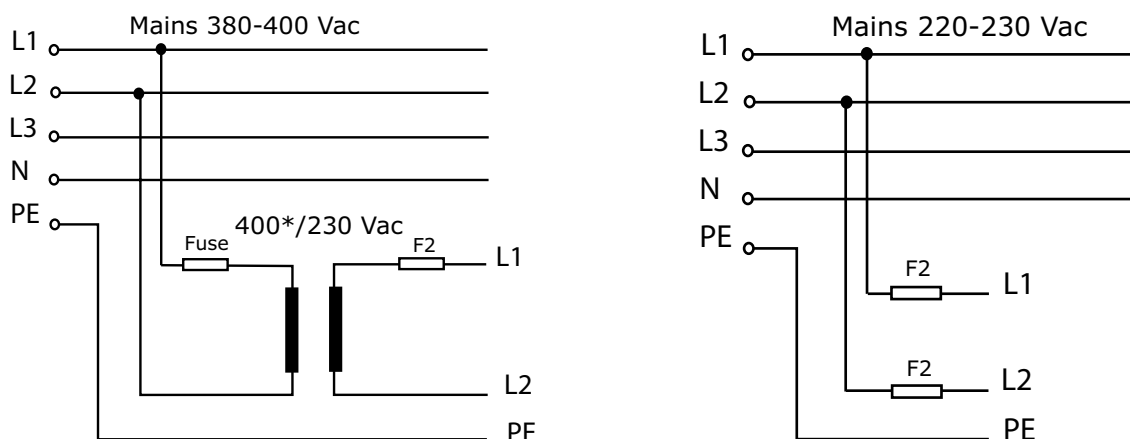

Notes:

- Insert protective fuses (F_2).
- **Always section all of the products' power phases, utilising a power relay or a thermal magnet. In the case of three phase the power relay or thermal magnet is applied to L1, L2 and L3.**
- Connect the pin **6 (PE)** to the ground bar of the system.
- Power cable must be shielded and the shield must be connected on both sides. Drive side the shield is connected to ground by connector; main supply side the shield must be connected on the zinc panel of the electrical box by u-clamp, after taking out a piece of the external sheat (see figure near here).

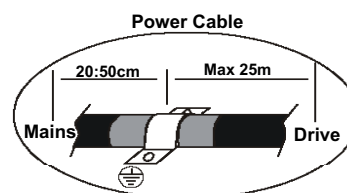

2.3 Power Supply connection

Note: The **nominal power of each motor** is calculated in this way:

$$P_n = n \times C_n / 9,55$$

P_n =nominal motor power [VA]

n = motor speed [rpm]

C_n = motor rated torque [Nm]

The **nominal power of the transformer** is calculated by adding the various wattage of each motor:

$$P_t = P_n + P_n + P_n + \dots$$

P_t = nominal power of the transformer [VA]

P_n = nominal power of each motor [VA]

Pin **3** on the **X1** connector is utilised for an **external power supply input**.

This Back-UP supply is utilised **to power the logic board** when the main supply is not available.

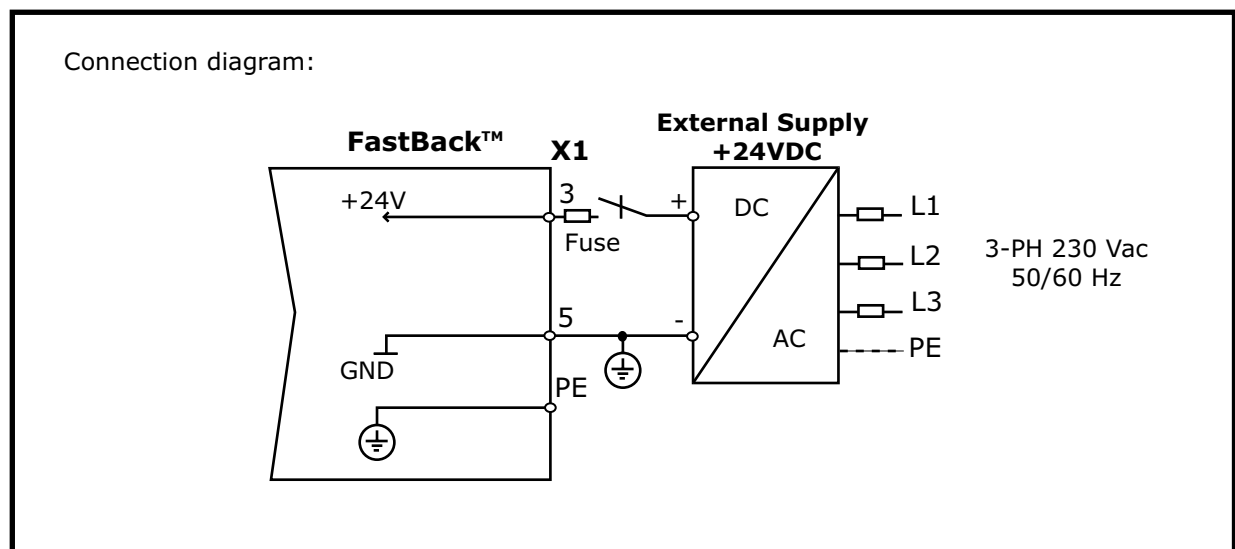

The **technical characteristics** of the Back Up input are the follows:

- The current's absorption on this terminal is **200mA** without brake and **1000mA** with brake.
- Input protected against polarity inversion.

Note: connect to the ground bar the 0V reference of the external supply.

2.4 IN/OUT Digital connection

The **X4 connector** of the **Fast Back™** manages two digital inputs and one digital output.

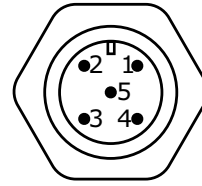

M12 male connector, X4
(Front view)

X4 connector - Digital inputs and output	
PIN	DESCRIPTION
1	Digital input, DGT-IN1
2	Programmable digital input, DGT-IN2
3	Digital output, DGT-OUT1
4	Digital inputs/output ground return
5	Earth/Shield, PE

The **Fast Back™** has **2 digital inputs (DGT-IN1 and DGT-IN2)**, which are opto-isolated. The input circuit is pre-disposed for **+24VDC-7mA** (PLC compatible). The range of enable is between **+14VDC Min.** and **+30VDC Max.**

Pin **X4-1 (ENABLE)** is used only as the drive's enable.

ATTENTION: THE DRIVE'S ENABLE/DISABLE, BY USING THE ENABEL INPUT, IS NOT CONSIDERED A SAFETY FUNCTION.

Pin **X4-2 (Programmable digital input)** can be used to activate pre-programmed functions of the drive. You can find more information about pre-programmed functions on enclosure "Additional Features Manual" available on the CD provided with the drive.

Connection to the Numerical Control:

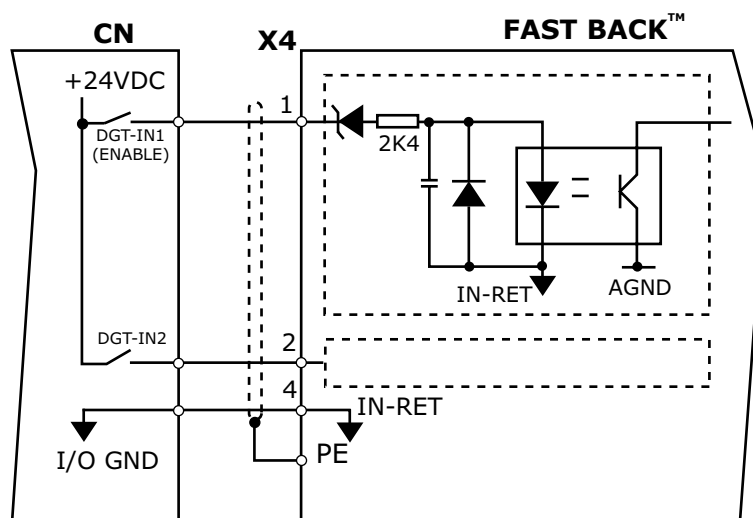

2.4 IN/OUT Digital connection

The **Fast Back™** has **one opto-isolated digital output (DGT-OUT1, +24Vdc-50mA, PLC compatible)**.

It is possible to utilise the digital output **to send messages from pre-programmed functions** of the drive.

In the figure below examples of some of the possible connections utilising this output are illustrated:

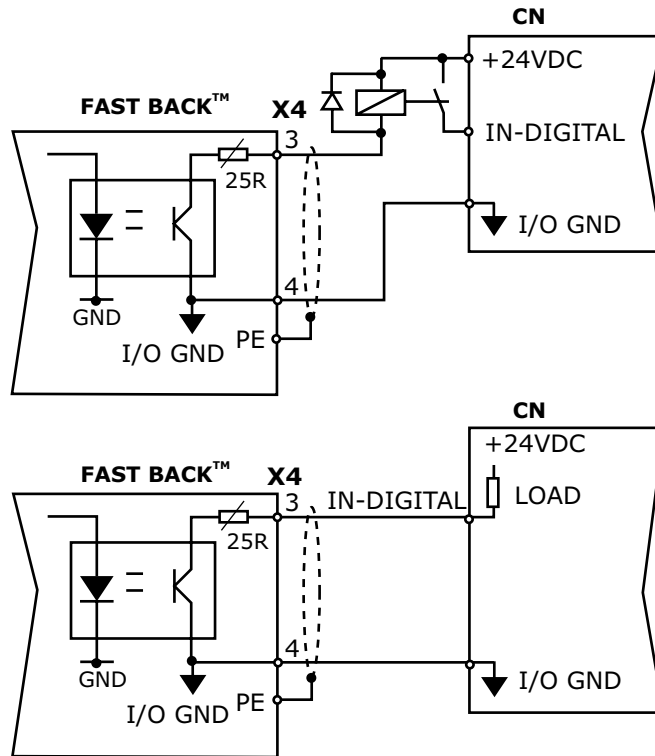

To set or enable the digital inputs **by software** or to visualise the **hardware status** of the digital output select "**Digital I/O**" in the main window of *Speeder One*.



2.5 Can Bus Interface

The **X2** and **X3** connectors of the **Fast Back™** manage the **IN/OUT** signals for **Can Bus** communication.

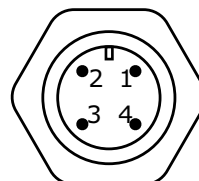

M12 male connector, X2 and X3
(Front view)

CanBus cable			
Drive side PINS X2/X3 M12	DESCRIPTION	WIRE COLOR	Control side PINS
2	LO CanBus channel, CAN L	White (SEE NOTE)	2
4	HI CanBus channel, CAN H	Brown (SEE NOTE)	4
3	Ground return (0V CAN)	Green	3
1	Earth/Shield, PE	Silver+Black sheathing	1

NOTE: White and brown wires must twisted.

On the **X2/X3** connectors an **interface for CANBus communication** is available (defined velocity 500kbit/sec, max. 1Mbit/sec).

The integrated software is based upon **CAN open DS301** communication protocol and on the **DSP402 profile**.

The CANOpen interface is isolated by opto-isolators and there is a dc-dc power converter that powers all of the circuitry of this interface. For this reason it is not necessary to connect any external supply. See the "**CanOpen Reference Manual**" available on the CD provided with the drive.

Can Bus SETTINGS:

To do a CanOpen Network you have to:

- set the **baud rate** parameter (in the "**General Settings**" window of the Speeder One interface), in order to define the communication speed and the performance of the system. All drives must have the same baudrate.
- set the **DEVICE-ID** (the "**Device-ID**" parameter in the "**General Settings**" window) to each drive. All drives must have a different DEVICE-ID.

2.5 Can Bus Interface

Can Bus CONNECTIONS

1. Connect the first **Fast Back™** to the MASTER using the CanBus cable (from the **X2** or **X3** connectors of the drive to the Master).
2. Connect each **Fast Back™** to the preceding and the following drive using the CanBus cables (**X2** and **X3** connectors).
3. Connect a **resistor** (120 Ohm) between pins **2** and **4** of the **X2** (or **X3**) connector of the the last **Fast Back™**.

Example:

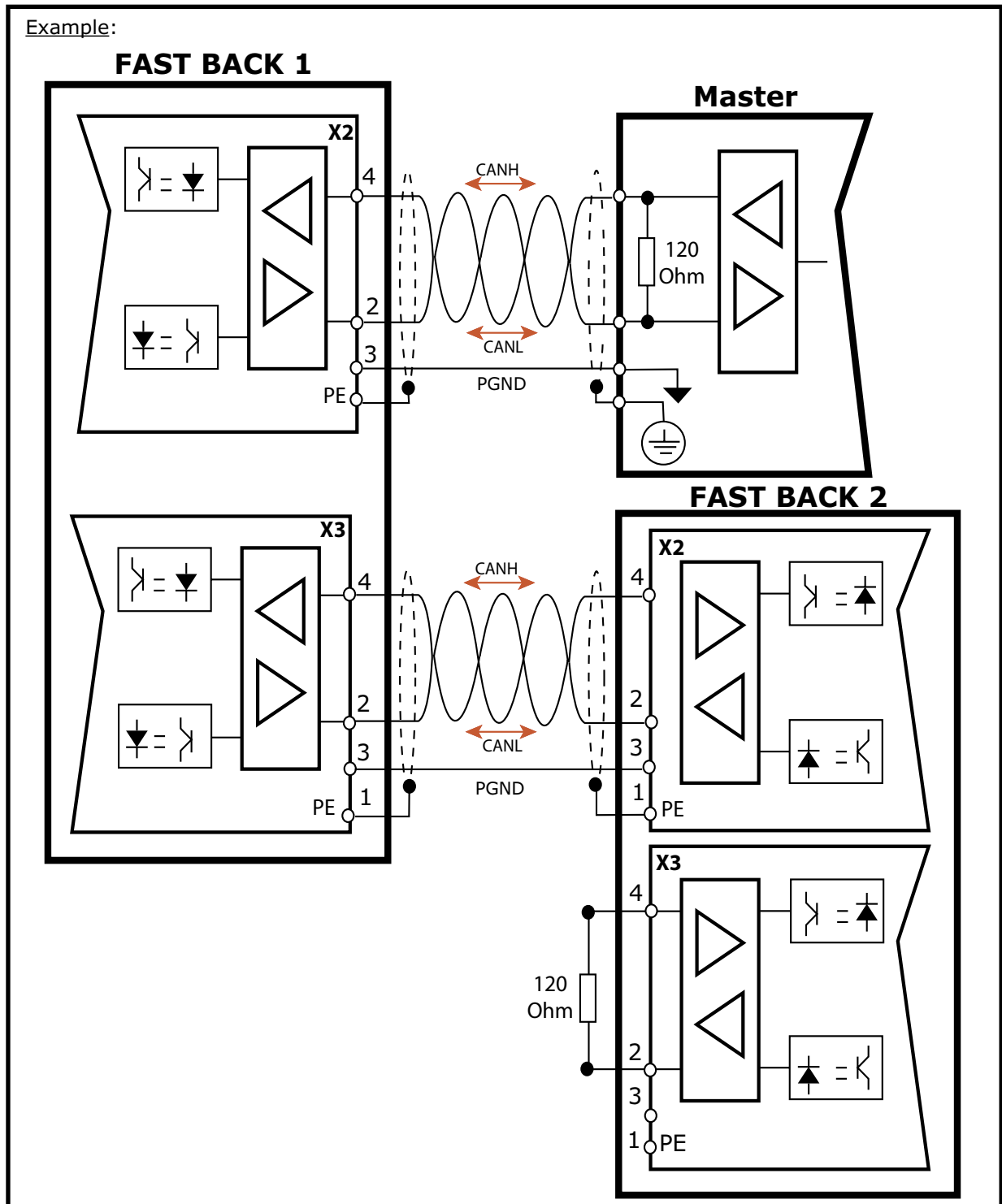

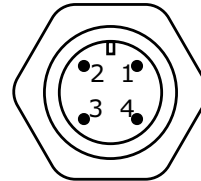

2.6 RS485 Interface

The **X2** and **X3** connectors of the **Fast Back™** manage also the **RS485** interface.



M12 male connector, X2 and X3
(Front view)

RS485 cable			
Drive side PINS X2/X3 M12	DESCRIPTION	WIRE COLOR	Control side PINS
2	Chanel B 485	White (SEE NOTE) 	2
4	Chanel A 485	Brown (SEE NOTE) 	4
3	Ground return (0V 485)	Green	3
1	Earth/Shield, PE	Silver+Black sheathing	1

NOTE: White and brown wires must twisted.

2.7 RS232 Interface

The **X5 connector** of the **Fast Back™** manages the **RS232 interface**.

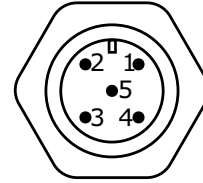

M12 male connector, X5
(Front view)

X5 connector - RS232 Interface	
PIN	DESCRIPTION
1	Chanel TXD RS232 interface
2	Chanel RXD RS232 interface
3	PGND
4	N.C.

The RS232 interface allows you to connect the **Fast Back™** to the *Speeder One* software interface and to insert all parameters of the drive (regulation, positioning, etc.) using the PC. This allows for communication via RS232 by **Mod BUS** protocol.

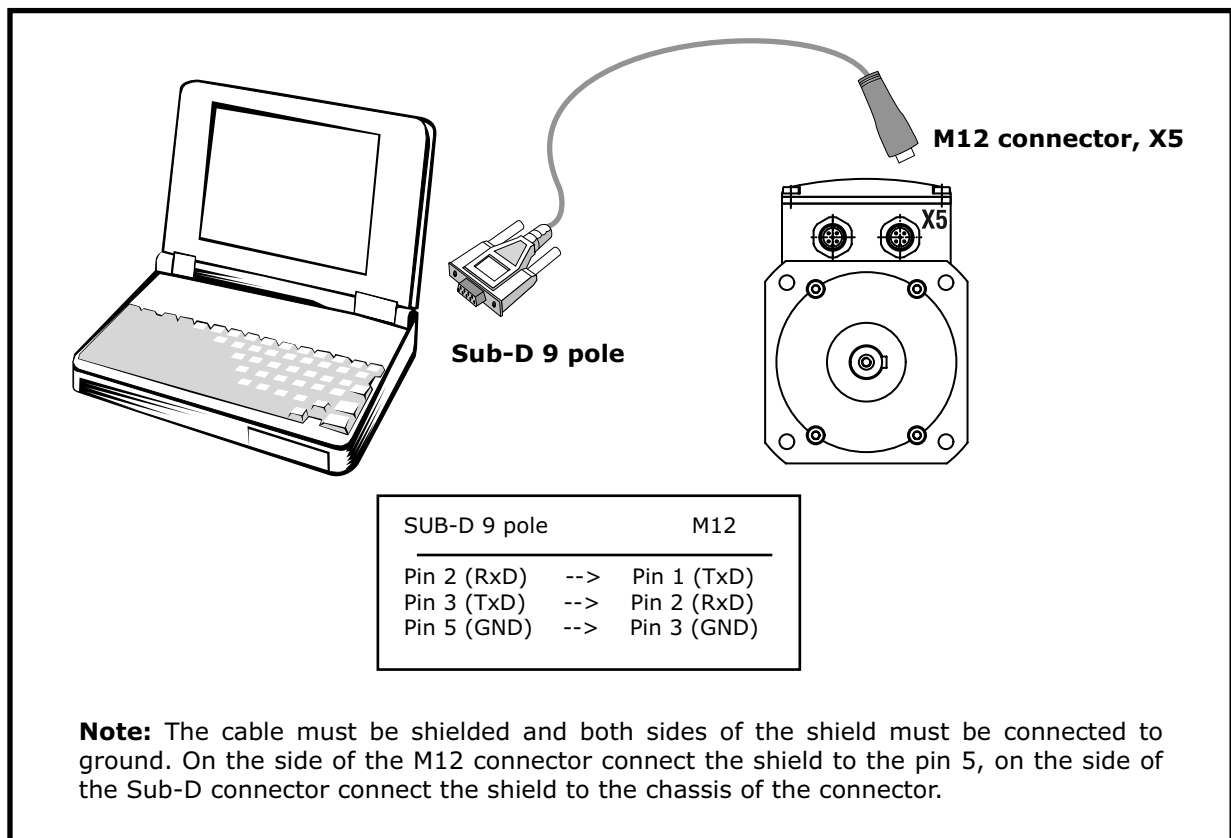

2.8 Multidrop

It is possible to communicate more than one Axor drive simultaneously with the "**Multi Drop connection**". This connection must take place between PC ("**MASTER**") and the first drive in **RS232** using the **MODBUS communication protocol**, while between the first drive and the other drives the communication will be copied utilizing **CAN BUS interface**.

In this way it is possible to set simultaneously the parameters of more drives.

The Axor drives use the **MODBUS** communication protocol specified in the **Modicon** instructions (see <http://www.modicon.com/techpubs/>).

Multidrop SETTINGS

In the "**General Settings**" window of each converter set:

1. **500 kbps** into the **Baudrate CAN bus** parameter;

2. the **Device ID** parameter. Each converter must have its **Device ID** parameter; it is convenient to set for the first drive connected to the PC in RS232 the **1** identification, while for the other drives it is convenient to set identifications in an incremental order.

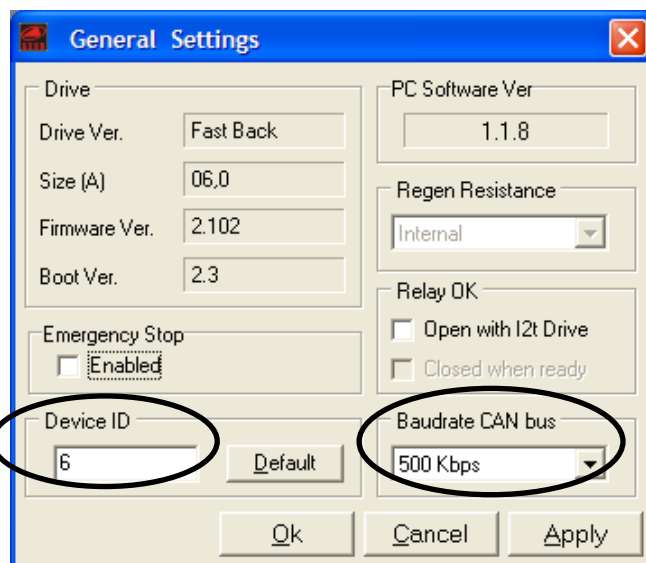

3. After these settings **save all to EEPROM** (using the "**Save Data to EEPROM**" icon), then **turn on and off the Fast Back™**.

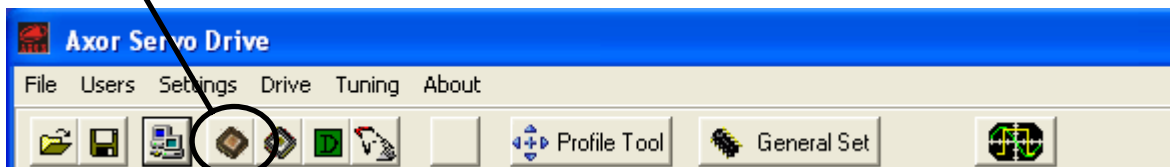

Multidrop CONNECTIONS

1. connect the first **Fast Back™** to the "**Master**" PC using the RS232 cable (**X5** connector);

2. connect each **Fast Back™** with the preceding and the following using the **X2** and **X3** connectors;

3. connect a **RESISTOR (120 Ohm)** between the **2** and **4** pins of the **X2** (or **X3**) connector of the **first Fast Back™** and another resistor between the **2** and **4** pins of the **X3** (or **X2**) connector of the **last Fast Back™**.

*(See connection diagram on the next page)

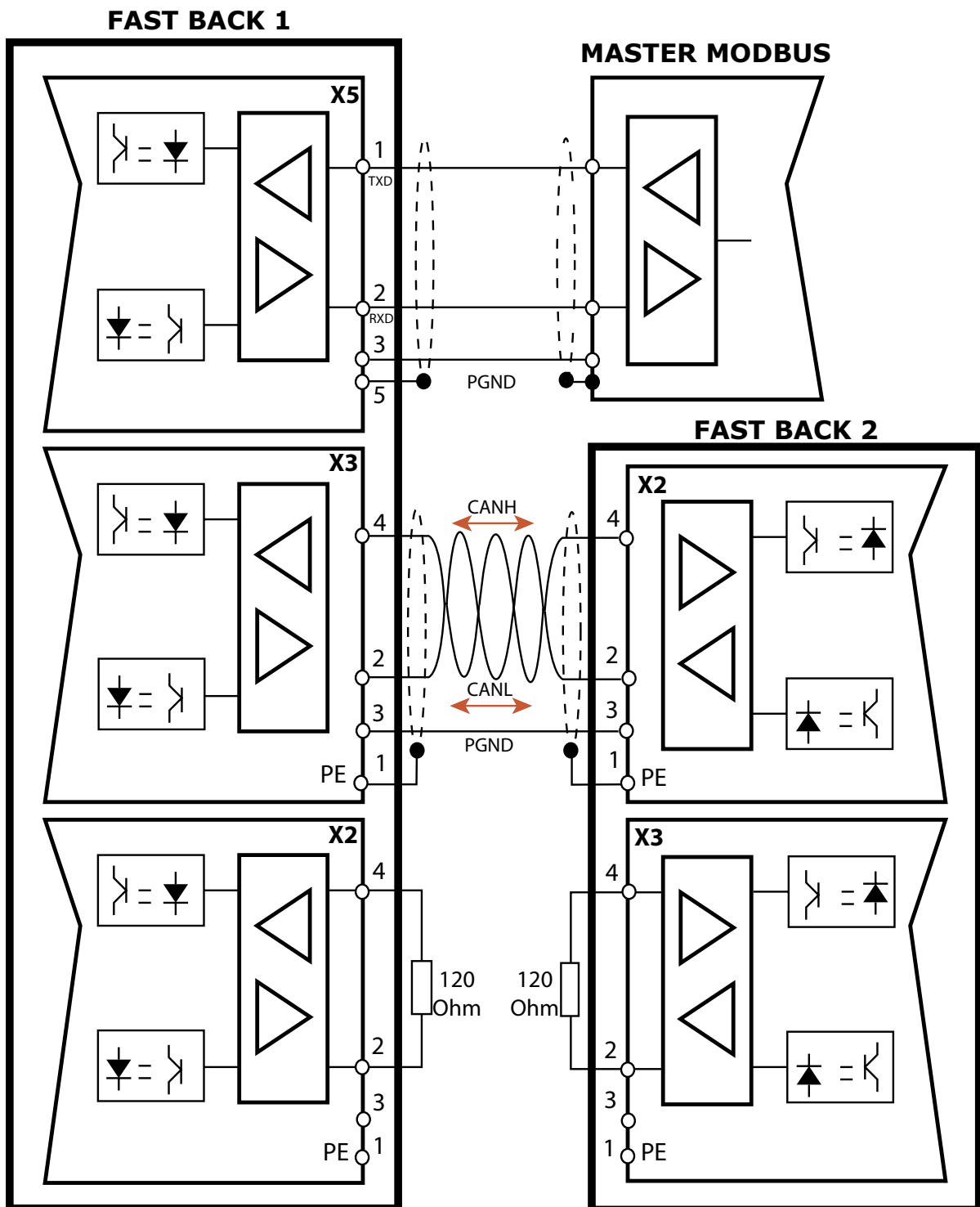

2.8 Multidrop

Example:



2.9 Led

In the **Fast Back™** there is a **LED** (red or green, fixed or blinking) that visualises the systems' status:

COLOR	STATE	CAUSE
No color	-	The Fast Back is turn off.
 (Green)	Blinking	There is only the +24Vdc auxiliary supply.
 (Green)	Fixed	The Fast Back is ready. The rotor is not running or it is running and there are not active alarms.
 (Red)	Fixed	There is an alarm.

During the start up of the system the led changes in this manner:

- 1) at the beginning it is switched off;
- 2) it becomes red because of the pre-loading phase;
- 3) it becomes green (fixed).

Chapter 3

Protections and Alarms

3.1 Protections	34
3.2 Alarms	35

3.1 Protections

Fast Back™ drives are equipped with a series of **protections** which safeguard both the drive and the motor in case of malfunctions.

There are three kinds of protection: **reversible**, **resettable** and **irreversible**.

Reversible protection intervention

It compares in presence of alarms which "reset itself" when the cause that has determined intervention is no longer present.

This causes the block of the drive. To restore the correct functioning it is necessary to:

- 1) disable the drive (using the "Disable" icon or the DGT-IN1 input);
- 2) eliminate the cause that has determined intervention;
- 3) enable the drive (using the "Enable" icon or the DGT-IN1 input).

Resettable protection intervention

It compares in presence of alarms which "can be reset" using the "Reset Fault" function.

This causes the block of the drive. To restore the correct functioning it is necessary to:

- 1) disable the drive (using the "Disable" icon or the DGT-IN1 input);
- 2) reset the alarm using the "Reset Fault" function;
- 3) enable the drive (using the "Enable" icon or the DGT-IN1 input).

Irreversible protection intervention

It compares in presence of alarms which "cannot be reset".

This causes the disabling of the drive. To restore the correct functioning it is necessary to:

- 1) Disconnect the power (main power supply and auxiliary power supply);
- 2) eliminate the cause of the block;
- 3) power again.

N.B. Before powering again wait a short while until the drive is securely switched off (the led must switch off).

3.2 Alarms

The table below illustrates all the message errors:

ERROR MESSAGES			
	Designation	Explanation	Reset
AL1	EEPROM	Error during the parameter memorising on the drive's eeprom. This causes the disabling of the functioning. This alarm resets itself memorising parameters on eeprom; if the alarm persists contact Axor.	Resets itself
AL2	Overcurrent	Short circuit between U, V, W or toward earth. This causes the disabling of the functioning. Disconnect the power, verify the wiring, then power again.	Cannot be reset
AL3	Drive Temperature	Heat sink temperature too high, >70°C. This causes the disabling of the functioning. Disable the drive, verify the forced ventilation functioning, verify the ambient temperature, wait that the radiator has cool off, reset the alarm then enable the drive.	Can be reset
AL4	Hall	This alarm goes on if one or more of the hall cell's wire is interrupted. This causes the disabling of the functioning. Contact Axor.	Contact Axor
AL5	Encoder	This alarm goes on if one or more of the incremental encoder channels are interrupted. There is a communication error with the absolute encoder. This causes the disabling of the functioning. Contact Axor.	Contact Axor
AL6	I²t Drive	The internal I ² t function has reached the maximum permitted, because of: <ul style="list-style-type: none"> • the working cycle could be too heavy; • a possible mechanical block; • a motor phases inversion; • the electronic brake not unblocked; • the amplifier dynamic constants: "KP", "KI" and "KD", could create useless current oscillation. This does not cause the disabling of the functioning.	Resets itself
AL7	Motor Temperature	Heat sink temperature too high. This causes the disabling of the functioning. Disable the drive: <ul style="list-style-type: none"> • control the heat sink temperature; • decrease the dynamic constant if the motor is vibrating. This situation causes the current oscillation and consequently the overheating of the motor. Wait the motor has cool off, reset the alarm, then enable the drive.	Can be reset
AL8	Regenerative Resistance	The value I ² t energy recovery has reached the maximum permitted. This causes the disabling of the functioning. Disable the drive: <ul style="list-style-type: none"> • check the AC power supply input; • check that the working cycles are not excessive; • verify if the motor, going at half speed, shows the same problem. Reset the alarm, then enable the drive.	Can be reset

3.2 Alarms

AL9	Min/Max Voltage	Minimum or maximum converter voltage. This causes the disabling of the functioning. Disable the drive, wait the DC power supply voltage reaches the correct threshold, check the AC power supply input, then enable the drive.	Resets itself
AL14	Following Error	The error between the position reference and the position feedback exceeds the "Max Position Error" parameter, because of the "Max Position Error" parameter is too small, or the dynamic gains of the velocity-positioning loop are wrong. This causes the disabling of the functioning. Disable the drive, check the Max Position Error parameter, check the dynamic gains, reset the alarm, then enable the drive.	Can be reset
AL15	Limit Switch	The fixed extra-run position is interrupted. This causes the disabling of the functioning. Disable the drive, check the end-run contact and external connections, then enable the drive.	Resets itself
AL23	Flash Alarm	Errors in reading/writing parameters on Flash, or Flash is empty. This causes the disabling of the functioning. Disable the drive, save new values, then re-enable. If the problem persists contact Axor.	Resets itself
AL24	Can Bus Alarm	Error during communication on CANBus. This causes the disabling of the functioning. Disable the drive, check the cabling and re-enable. If the problem persists contact Axor.	Can be reset by CAN
AL26	Homing Error	Position error too high during the homing procedure. The motor stops, but it is not disabled. Check the homing setup, then reset the alarm using the "Start Homing" function.	Can be reset by "Start Homing"

Index

B

Back Up supply
connections 23
connector 21

C

CanBus interface
connections 27
Conformity 39

D

Digital inputs 6
connection 24
Digital output 6
connections 25
Disposal 18

E

EMI filter 7

F

Fuses 10, 11

L

Led 32

M

Maintenance 18
Mechanical curves 13, 14
Multidrop
connections 30
settings 30

O

Operative Modes 6
CanBus 6
multidrop RS232 6
position control 6
RS485 interface 6
speed control 6
Torque control 6

P

Power Supply
connections 21
connector 21
Product plate 15
Protections 34

Index

R

RS232 Interface 29
RS485 Interface 28

S

Safety
 safety enable function 7
Storage 18

T

Transport 18

Conformity

European directives and norms

The servodrives are intended to be incorporated into electrical plant and machines for industrial use. When the servodrive is used into machines or plant, the electrical plant/machine must respect the following directives: **EC Machinery Directive (2006/42/EC)**, **EC Directive on EMC (2004/108/EC)**, **Low Voltage Directive (2006/95/EEC)**.

The machine/plant manufacturer must examine whether with its machine/plant still further or other standards or EEC guidelines are to be used.

EC Conformity

The **EC** mark that is applied to the drives references to the **Low Voltage Directive (2006/95/EC)** and **EC Directive on EMC (2004/108/EC)**.

The standard EN 61800-5-1 is applied to ensure conformance with the Low Voltage Directive.

The standard EN 61800-3 is applied to ensure conformance with the EMC Directive.

In reference to noise immunity and noise emission the converters fulfil the requirement to the category *second environment* (industrial environment).

If the installation of the drive is carried out differently than described in this manual, the user must carry out new measures to satisfy the requisites of law.



AXOR INDUSTRIES®

viale Stazione, 5
36054 Montebello Vic.
Vicenza - Italy

phone (+39) 0444 440441
fax (+39) 0444 440418
info@axorindustries.com

www.axorindustries.com



UWE 	Postfach 1967 D-77909 LAHR Schützenstr. 14a D-77933 LAHR
	Tel.: 07821 / 98 39 13 Fax: 07821 / 98 39 14 Funk: 0171 80 38 472 Mail: info@pophof.de www.pophof.de
POPHOF ANTRIEBSTECHNIK & AUTOMATION	